



# TOWN OF LEDYARD CONNECTICUT

741 Colonel Ledyard Highway  
Ledyard, Connecticut 06339-1551  
(860) 464-3203  
council@ledyardct.org

## Town Council ~ AGENDA ~

Chairman Gary St. Vil

Regular Meeting

---

Wednesday, May 27, 2026

7:00 PM

Town Hall Council Chambers

---

**In-Person: Council Chambers Town Hall Annex**

**Remote: Information noted below:**

**Join Zoom Meeting from your Computer, Smart Phone or Tablet:**

**<https://ledyardct.zoom.us/j/84125159570?pwd=4k8810gSHvJwp5Uk6xuIBKs3gbIbuD.1>**

**Audio Only: Telephone: +1 646 558 8656; Meeting ID: 841 2515 9570; Passcode: 465490**

- I. CALL TO ORDER
- II. PLEDGE OF ALLEGIANCE
- III. ROLL CALL
- IV. PRESENTATIONS
- V. RESIDENT & PROPERTY OWNERS (COMMENTS LIMITED TO THREE (3) MINUTES)
- VI. COMMITTEE COMMISSION AND BOARD REPORTS
- VII. COMMENTS OF TOWN COUNCILORS
- VIII. REVIEW AND APPROVAL OF MINUTES

MOTION to approve the Town Council Regular Meeting Minutes of May 13, 2026

- IX. COMMUNICATIONS

Communications List May 27, 2026

- X. REFERALS
- XI. COUNCIL SUB COMMITTEE, LIAISON REPORTS
  - 1. Administration Committee Report Fiscal Year 2025/2026
  - 2. Community Relations Committee for Diversity, Equity & Inclusion – Report- Fiscal Year 2025/2026
  - 3. Finance Committee Report Fiscal Year 2025/2026

## 4. LUPPW Committee Report Fiscal Year 2025/2026

Liaison Reports

## XII. REPORT OF THE MAYOR

Mayor Report Fiscal Year 2025/2026

## XIII. OLD BUSINESS

## XIV. NEW BUSINESS

Administration Committee

1. MOTION to approve proposed Social Services Coordinator job description as presented in the draft date May 5, 2026.

**Attachments:** [Social Services Coordinator DRAFT 5-5-26.pdf](#)

2. MOTION to endorse the Parks, Recreation & Senior Citizens Commission proposal to dedicate the new pavilion Lantern Hill Road Park in Janet Barnett (Janet Barnett Pavilion)

**Attachments:** [FD#4 IWWC#25-6SITE SitePlan-Lantern Hill Road park](#)  
[TS-G1220-04-Preliminary-Pavilion-Lantern Hill Park](#)  
[Janet Barnett - grant request to Park and Rec](#)

3. MOTION to endorse the Parks, Recreation & Senior Citizens Commission proposal to dedicate the Senior Center Fitness Room in Paula Crocker (Paula Crocker Fitness Center).
4. MOTION to recommend the Town Council appoint the following Members to the “Ad Hoc Committee to Evaluate the Separation of the Planning Commission & Zoning Commission” a for six-month term in accordance with Res#002-2026/Mar 25

- One Member from the Community-at-Large with Planning experience:  
Mr. Tony Capon (D) 37 Silas Deane Road, Ledyard

- One Member from the Community-at-Large with Zoning experience  
Mr. Kevin Dombrowski ( R) 139 Meetinghouse Lane, Ledyard

- One Member from the Planning & Zoning Commission  
Ms. Beth Ribe (U) 129 Rose Hill Road, Ledyard

- One Member from the Community-at-Large  
Mr. Milton (Dave) Schroder, Jr., (U) 290 Whalehead Road, Gales Ferry

- One Member from the Town Council )

**Attachments:** [APPOINT APPLICATION-CHERRY-EVALUATE SEPARATE PLANNING AND ZONING COMMISISON AD HOC CMT-2026-03-31](#)  
[APPOINT APPLICATION-CAPON-EVALUATE SEPARATE PLANNING AND ZONING COMMISISON AD HOC CMT-2026-03-31](#)  
[DTC-Approve Appoint Applcations-Kulo & Capon- Evaluate Seperate Planning & Zoning Commissions-email-2026-05-06](#)  
[APPOINT APPLICATION-KULO-EVALUATE SEPARATE PLANNING AND ZONING COMMISISON AD HOC CMT](#)  
[RTC-Appointment Application-Dombrowski-Evaluate Seperate Planning & Zoning Commission-2026-03-31](#)  
[RTC-APPOINT APPLICATION-TREASTER-AD HOC Committee Planing and Zoning - 2025-04-10](#)  
[RIBE-PLANNING & ZONING REP-AD HOC COMMITTEE TO EVALUATE SEPERATE PLANNING & ZONING COMMISSION-LTR-2026-04-15](#)  
[APPOINT APPLICAITON-SCHROEDER-EVALUATE SEPERATE PLANNING AND ZONING COMMISISON AD HOC CMT](#)  
[APPOINT APPLICATION-MURRAY-EVALUATE SEPARATE PLANNING AND ZONING COMMISISON AD HOC CMT-2026-04-19](#)  
[RTC-APPOINT APPLICAITON-MURRAY-EVALUATE SEPERATE PLANNING AND ZONING COMMISISON AD HOC CMT-2026-05-11](#)

5. MOTION to appoint Mr. David Gruszkowski ( R) 26 Saw Mill Drive, Ledyard, to the Retirement Board to complete a three (3) year term ending January 20, 2029 filling a vacancy left by Ms. DeGaetano.

**Attachments:** [RTC-APPOINT APPLICATION-GRUNSKOWSKI-RETIEREMENT BOARD-2026-04-03](#)  
[RETIREMENT BOARD-2026-04-06](#)

6. MOTION to appoint Mr. Gary Schneider (D) 101 Inchcliffe Drive, Gales Ferry to the “Ad Hoc Committee to Develop a Process for Capital Improvement Budding Projects for the Town of Ledyard” as the Representative from the Community at Large, for six-month term in accordance with Res#002-2026/Feb 11.

**Attachments:** [APPOINT APPLICAITON-SCHNEIDER-AD HOC CMT-CAPITAL BULDING PROCESS-2026-05-03](#)  
[DTC-ENDORSE SCHNEIDER APPOINT APPLICAITON-AD HOC CMT-DEVELOP PROCESS FOR CAPITAL IMPROMVENT PROJECTS-2026-05](#)  
[Gary Schneider-Resume'](#)  
[002-2026-FEB-11-RES-AG-AD HOC CMT-BUILDING PROJECTS AD HOC COMMITTEE-2026-05-04](#)

7. MOTION to appoint Ms. Anne Roberts-Pierson (U) 4 Anderson Drive, Gales Ferry, as a Regular Member to the Historic District Commission, to complete a five (5) year term ending December 6, 2029; filling a vacancy left by Ms. Lamb.

**Attachments:** [HISTOIRC DISTRICT COMMISSION-APPOINT ALTERNATE ROBERTS-PIERSON TO REGULAR MEMBER-EMAIL-2026-05-05](#)  
[Resignation-K-Lamb-Historic District Commission-email-2026-04-16](#)

8. MOTION to appoint Ms. Kim Millar (U) 6 Riverside Place, Gales Ferry, as an Alternate Member to the Historic District Commission, to complete a five (5) year term ending December 6, 2028; filling a vacancy left by Ms. Roberts-Pierson.

**Attachments:** [APPOINT APPLICATION-MILLAR-HISTOIRC DISTRICT COMMISSION 2026-05-05](#)  
[HISTORIC DISTRICT COMMISSION-2026-05-04](#)  
[Resignation-K-Lamb-Historic District Commission-email-2026-04-16](#)

9. MOTION to reappoint Ms. Sarah Martic ( R) 59R Long Pond Road, South, Ledyard, to the Ledyard Farmers' Market Committee for a three (3) year term ending May 9, 2029.

**Attachments:** [Re-Appointment Endorsement- Farmers Market Cmt-2026-05-05](#)

10. MOTION to appoint Mr. Jeremy Norris (D) 12 Old Fort Lane, Ledyard, as an Alternate Member to the Ledyard Farmers' Market Committee to complete a three (3) year term ending February 26, 2029 filling a left by Mr. Hary.

**Attachments:** [APPOINT APPLICATION-NORRIS-FAMRERS MARKET COMT-2026-05-02](#)  
[DTC-Approve Appoint Applications-Norris-Farmers Market Cmt & Carol Schneider-Reappoint-Parks-Rec & Senior Citizens- email-2026-05-06](#)  
[FARMES MARKET-2026-05-04](#)

#### Finance Committee

11. MOTION to authorize the expenditure of up to \$7,000 from Account #21090305-58920 (Acquisition of Open Space) to support a Long Pond Invasive Species Study.

12. MOTION to authorize the Mayor to enter into a Listing Agreement with a Realtor to list 89 Town Farm Road for sale.

**Attachments:** [Tax Map- 89 Town Farm Road](#)  
[89 Town Farm with Wetlands soils and floodway overlay](#)

13. MOTION to MOTION to establish a new Board of Education Non-Lapsing Fund in accordance with CGS 171-10-248.

**Attachments:** [Public Act-24-45-Education Non-Lapsing Account-House Bill 5437](#)  
[Sec. 10-248a. Unexpended education funds account-Non-lapsing Account](#)  
[Chairman St. Vil-Board of Education Budget Surplus & Eversource](#)  
[Reimbursement-Finance Director-email-2026-05-05](#)  
[Board of Education Fiscal Year 2024-2025 Budget Sruplus](#)  
[Transfer-ltr-2026-03-30](#)  
[Finance Director response to BOE communication dated March 30 2026](#)  
[Resolution- Board of Education Capital Account-09-1988](#)

14. MOTION to appropriate and transfer the Board of Education's Fiscal Year 2024/2025 Audited Surplus in the amount of \$212,031 from Undesignated Fund Balance) to the newly

established Board of Education Fund.

**Attachments:** [Chairman St. Vil-Board of Education Budget Surplus & Eversource Reimbursement-Finance Director-email-2026-05-05](#)  
[Board of Education Fiscal Year 2024-2025 Budget Surplus Transfer-ltr-2026-03-30](#)  
[Finance Director response to BOE communication dated March 30 2026](#)

15. MOTION to transfer Eversource Reimbursement in the amount of \$19,943 from Undesignated Fund Balance to the Board of Education's Capital Non-Reoccurring Account.

**Attachments:** [Chairman St. Vil-Board of Education Budget Surplus & Eversource Reimbursement-Finance Director-email-2026-05-05](#)  
[Board of Education Fiscal Year 2024-2025 Budget Surplus Transfer-ltr-2026-03-30](#)  
[Finance Director response to BOE communication dated March 30 2026](#)

#### General Business

16. Discussion regarding the Town Council's 2026 Summer Meeting schedule.

#### XV. ADJOURNMENT

#### **DISCLAIMER:**

Although we try to be timely and accurate these are not official records of the Town.

The Town Council's Official Agenda and final Minutes will be on file in the Town Clerk's Office.



# TOWN OF LEDYARD

741 Colonel Ledyard  
Highway  
Ledyard, CT 06339-1511

---

**File #:** 26-0739

**Agenda Date:** 5/27/2026

**Agenda #:**

---

## MINUTES

**Minutes:**

MOTION to approve the Town Council Regular Meeting Minutes of May 13, 2026



# TOWN OF LEDYARD

741 Colonel Ledyard  
Highway  
Ledyard, CT 06339-1511

---

**File #:** 26-0736

**Agenda Date:** 5/27/2026

**Agenda #:**

---

AGENDA ITEM  
CORRESPONDENCE

**Subject:**

Communications List May 27, 2026

**Correspondence List:**

(type text here)



# TOWN OF LEDYARD

741 Colonel Ledyard  
Highway  
Ledyard, CT 06339-1511

---

**File #:** 25-2156

**Agenda Date:** 6/10/2026

**Agenda #:** 1.

---

## REPORT

**Staff/Committee Report: Administration Committee Reports Fiscal Year 2025/2026**  
Administration Committee Report Fiscal Year 2025/2026



# TOWN OF LEDYARD

741 Colonel Ledyard  
Highway  
Ledyard, CT 06339-1511

---

**File #:** 25-2157

**Agenda Date:** 5/27/2026

**Agenda #:** 2.

---

## REPORT

### **Staff/Committee Report: Community Relations -DEI Reports Fiscal Year 2025/2026**

Community Relations Committee for Diversity, Equity & Inclusion - Report- Fiscal Year 2025/2026



# TOWN OF LEDYARD

741 Colonel Ledyard  
Highway  
Ledyard, CT 06339-1511

---

**File #:** 25-2159

**Agenda Date:** 5/27/2026

**Agenda #:** 3.

---

## REPORT

**Staff/Committee Report: Finance Committee Reports Fiscal Year 2025/2026**

Finance Committee Report Fiscal Year 2025/2026



# TOWN OF LEDYARD

741 Colonel Ledyard  
Highway  
Ledyard, CT 06339-1511

---

**File #:** 25-2160

**Agenda Date:** 5/27/2026

**Agenda #:** 4.

---

## REPORT

**Staff/Committee Report: LUPPW Committee Reports Fiscal Year 2025/2026**

LUPPW Committee Report Fiscal Year 2025/2026



# TOWN OF LEDYARD

741 Colonel Ledyard  
Highway  
Ledyard, CT 06339-1511

---

**File #:** 25-2161

**Agenda Date:** 5/27/2026

**Agenda #:**

---

## REPORT

**Staff/Committee Report: Mayor Reports Fiscal Year 2025/2026**  
Mayor Report Fiscal Year 2025/2026



# TOWN OF LEDYARD

741 Colonel Ledyard  
Highway  
Ledyard, CT 06339-1511

---

**File #:** 26-0641

**Agenda Date:** 5/27/2026

**Agenda #:** 1.

---

## JOB DESCRIPTION

**Motion/Request:**

MOTION to approve proposed Social Services Coordinator job description as presented in the draft date May 5, 2026.

**Background:**

This new position has been included in the FY2027 budget to serve as both the Municipal Agent and provide social services assistance for the residents of Ledyard. The position will be part time and non-union.

**Department Comment/Recommendation:**

The job description was created by the Mayor's Office and the Director of Human Resources.

**Human Resources Comment/Recommendation:**

The Director of Human Resources recommends the approval of the job description as presented.

**Financial Information:**

(type text here)

**Mayor Comment/Recommendation:**

(type text here)

**TOWN OF LEDYARD  
SOCIAL SERVICES COORDINATOR**

**NATURE OF WORK:**

This is a highly responsible position, dealing with complex and confidential information in planning, administering and organizing social service programs by the Ledyard Social Services.

**SUPERVISION RECEIVED:**

Receives general direction from the Mayor. Assignments are generally independently prioritized and accomplished.

**SUPERVISION EXERCISED:**

Coordination of community service volunteers

**ESSENTIAL JOB FUNCTIONS:**

Administers the social service program in the functional areas of emergency assistance and case management to individuals and families in need. Assists the public in response to requests for service, referrals, as well as complaints. Screens and directs calls to the appropriate service provider within the department or outside agency(s). Receives and endeavors to resolve citizen complaints and need for services. Works closely with the public and volunteers in the coordination, receipt and distribution of food donations to the food pantry.

Prepares, organizes and administers, all Holiday and Seasonal Programs including the backpack program, Holiday Baskets, Toy Drive and Adopt A family.

Administers the human service programs in the areas of emergency assistance to individuals and families in need in the community, through Ledyard Inter-Church Emergency Assistance Fund, (LICEAF).

Enters and records all confidential client and clinical information, including reports to the Town, State or other official agencies. Maintains all confidential client case files and ensures the protection of the sensitive information relating to the client's circumstances.

Establishes and maintains appropriate working relationships with State and Federal officials, Town officials, public offices, the general public, consultants, other departments, and agencies.

Act as Municipal Agent for the Town of Ledyard. Assists town residents ages 60+ by providing information and referrals to local, state, and federal services and benefit programs. Municipal Agents are familiar with programs and benefits such as Medicare, Medicaid, SNAP (Food Stamps), Social Security, protective services, legal services, adult day care, housing, transportation, and local senior and community groups. Many also help seniors fill out application forms for benefits.

## **QUALIFICATIONS PROFILE:**

### Knowledge, Skills and Ability

Skills and knowledge required in this position would generally be acquired with a Bachelor's Degree in Social Services, Public Administration, or closely related field, with three years of social services program administration experience, or a combination of the aforementioned education and practical experience totaling five years of progressively responsible social services program administration experience.

Knowledge of local government organizations as well as state and federal programs.

Ability to analyze, interpret and implement laws and regulations. The ability to acquire a working knowledge of community resources and opportunities. Accurate records must be maintained, and general reports must be prepared with the ability to exercise discretion in handling confidential information.

Proficient use of computer software used in the Town Hall as applied to office applications, internet applications and the ability to acquire knowledge of Town financial and record keeping systems within a reasonable period of time.

Ability to establish and maintain effective and courteous working relationships with public officials, residents, members of the general public, other agencies, co-workers, and subordinates, and to effectively and discreetly convey information as required.

Ability to regularly engage in activities necessitated by the position outside of normal business hours, i.e., evening meetings, emergencies, etc.

### **LICENSE OR CERTIFICATE**

Valid Motor Vehicle Operator's License.

### **PHYSICAL DEMANDS**

The physical demands described here are representative of those that must be met by an employee to successfully perform the essential functions of this job.

While performing the duties of this job, the employee is frequently required to speak and hear; walk; sit; stand; bend; stoop; kneel, use hands and fingers to handle, feel or operate objects, tools or controls; reach with hands and arms, use wrist for repetitive motion. The employee must occasionally lift and/or move up to 20 pounds. Specific vision abilities required by the job include close vision and the ability to adjust focus. Hand/eye coordination is necessary to operate computer and various pieces of office equipment.

The employee must be free from mental and/or physical disorder which would interfere with the performance of duties as described, and have the ability to maintain his/her composure with the public and co-workers in every day stressful and emergency situations. Employee may occasionally have to function in situations where subjected to aggressive verbal behavior.



# TOWN OF LEDYARD

741 Colonel Ledyard  
Highway  
Ledyard, CT 06339-1511

---

**File #:** 26-0617

**Agenda Date:** 5/27/2026

**Agenda #:** 2.

---

AGENDA REQUEST  
GENERAL DISCUSSION ITEM

**Subject:**

MOTION to endorse the Parks, Recreation & Senior Citizens Commission proposal to dedicate the new pavilion Lantern Hill Road Park in Janet Barnett (Janet Barnett Pavilion)

**Background:**

(type text here)

**Department Comment/Recommendation:**

(type text here)

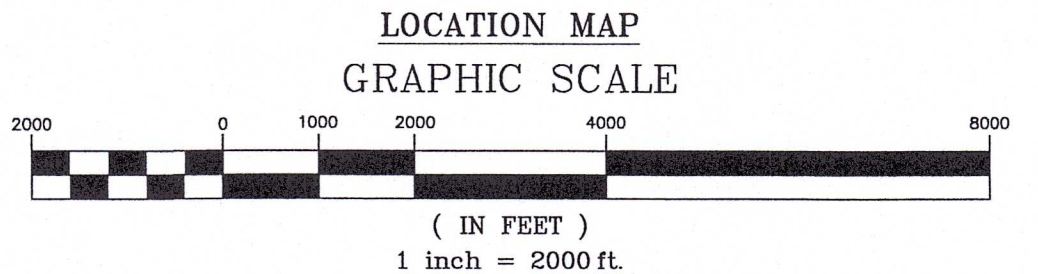
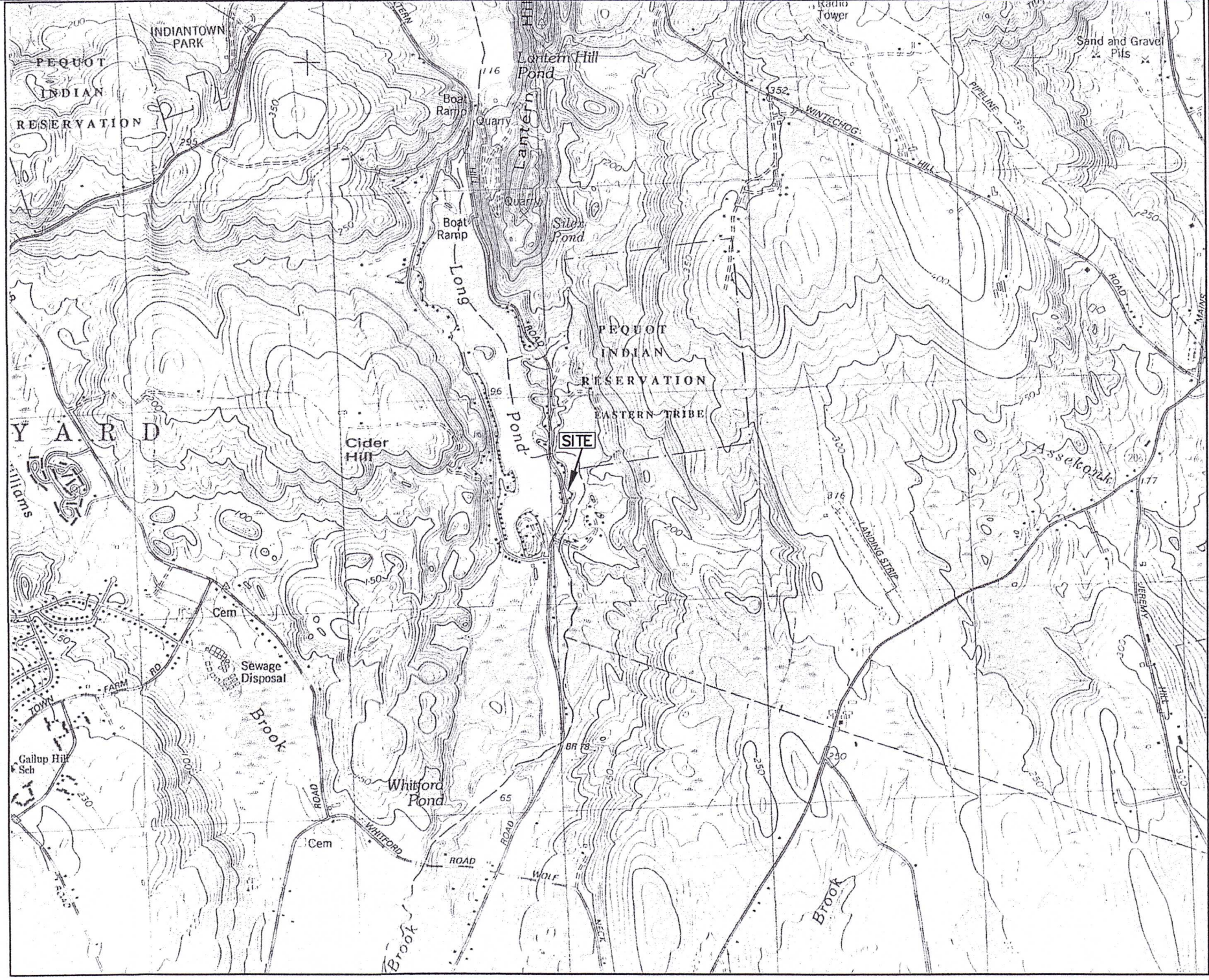
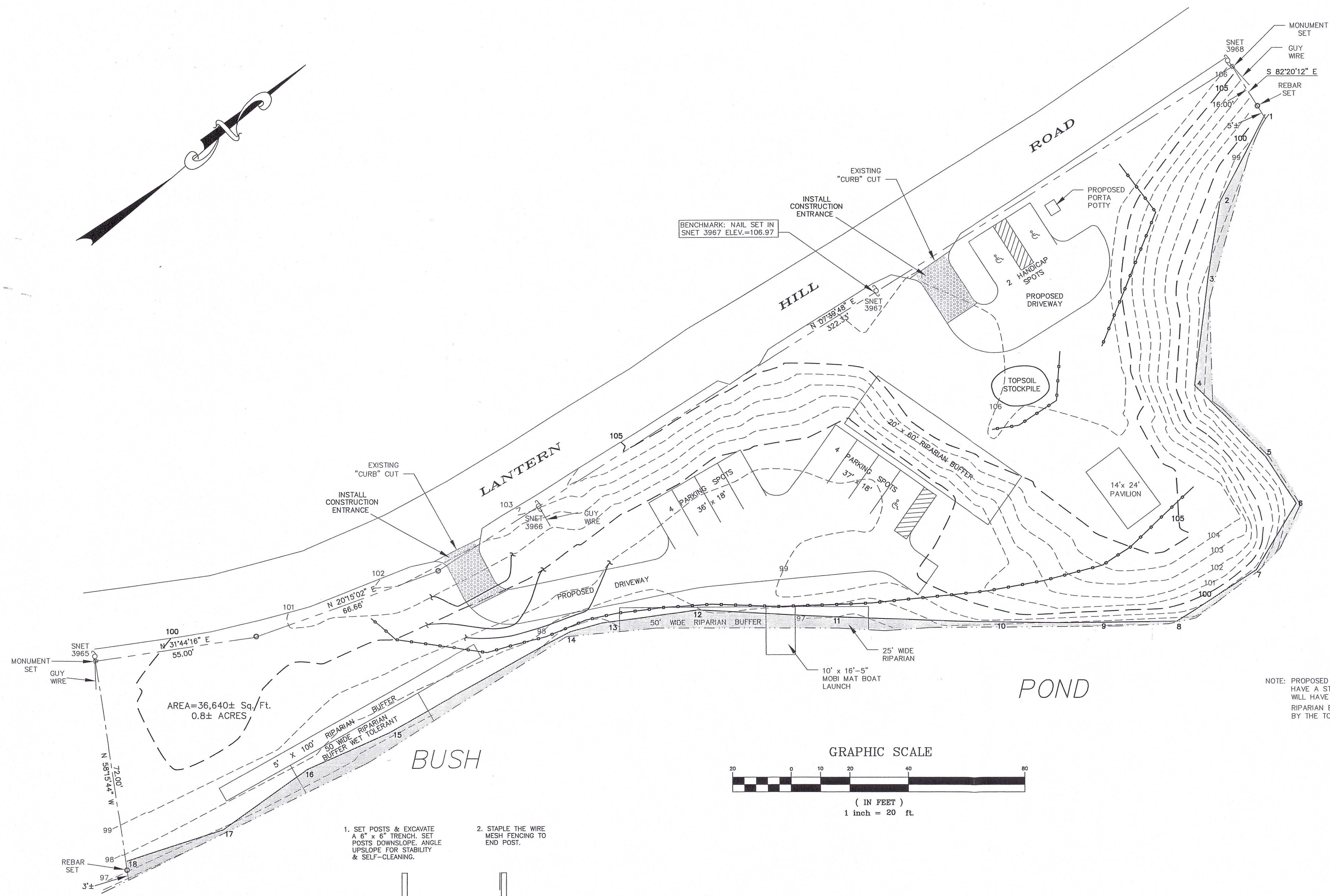
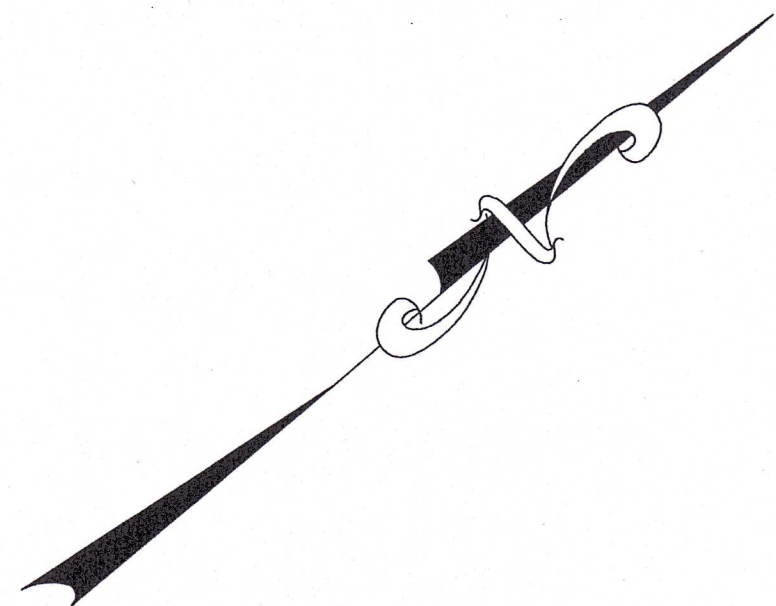

AREA = 36,840 ± Sq. Ft.  
0.8 ± ACRES

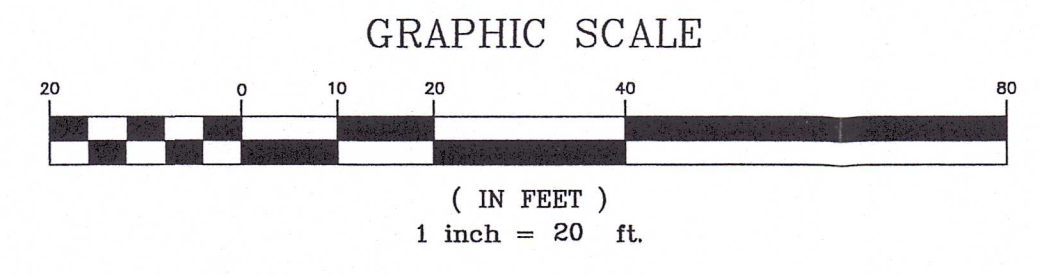

NOTE: PROPOSED DRIVE IS 12 FEET WIDE AND WILL HAVE A STONE SURFACE. HANDI-CAP SPACES WILL HAVE STONE DUST SURFACE. RIPARIAN BUFFERS SHOWN ARE AS REQUESTED BY THE TOWN OF LEDYARD.

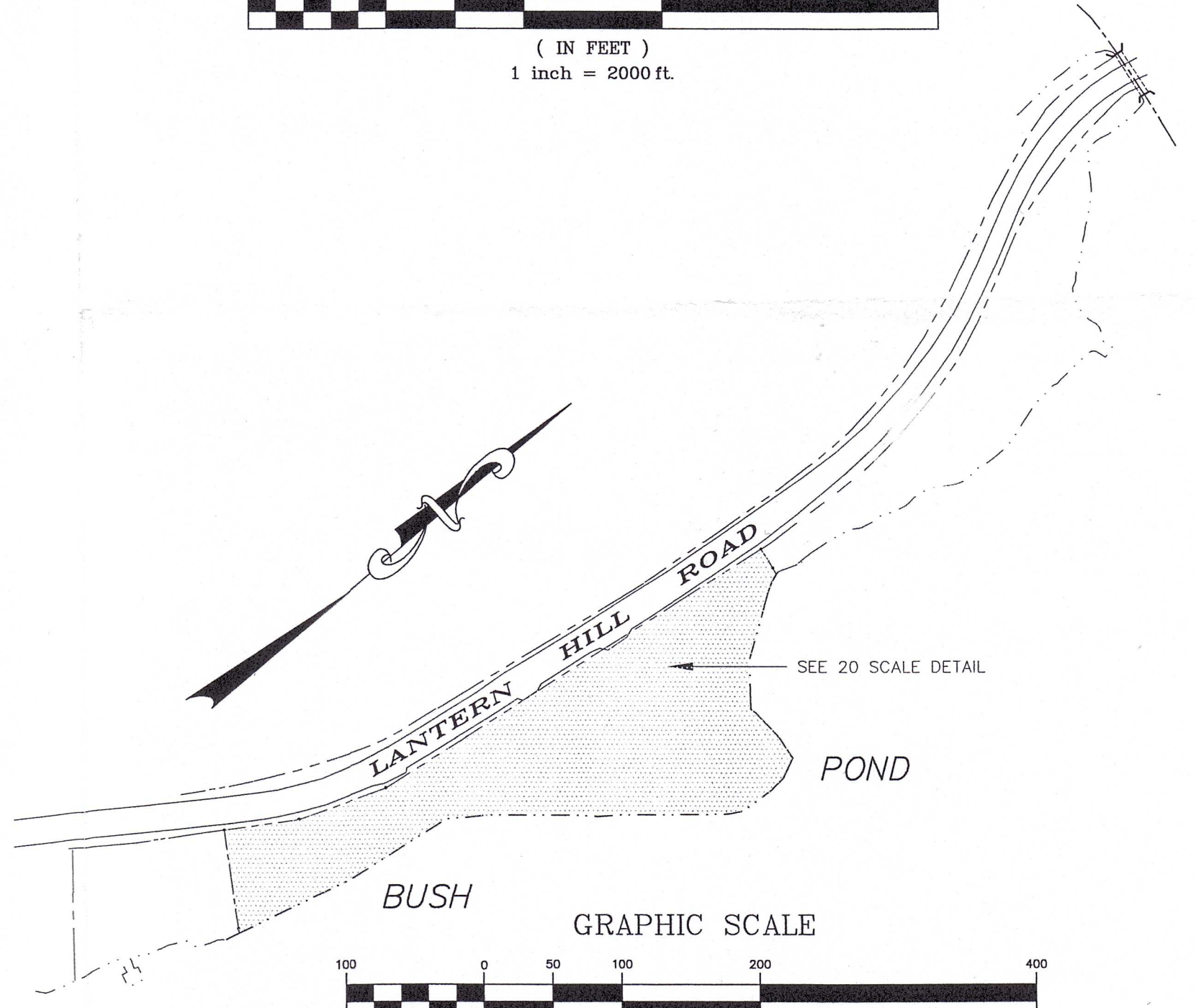
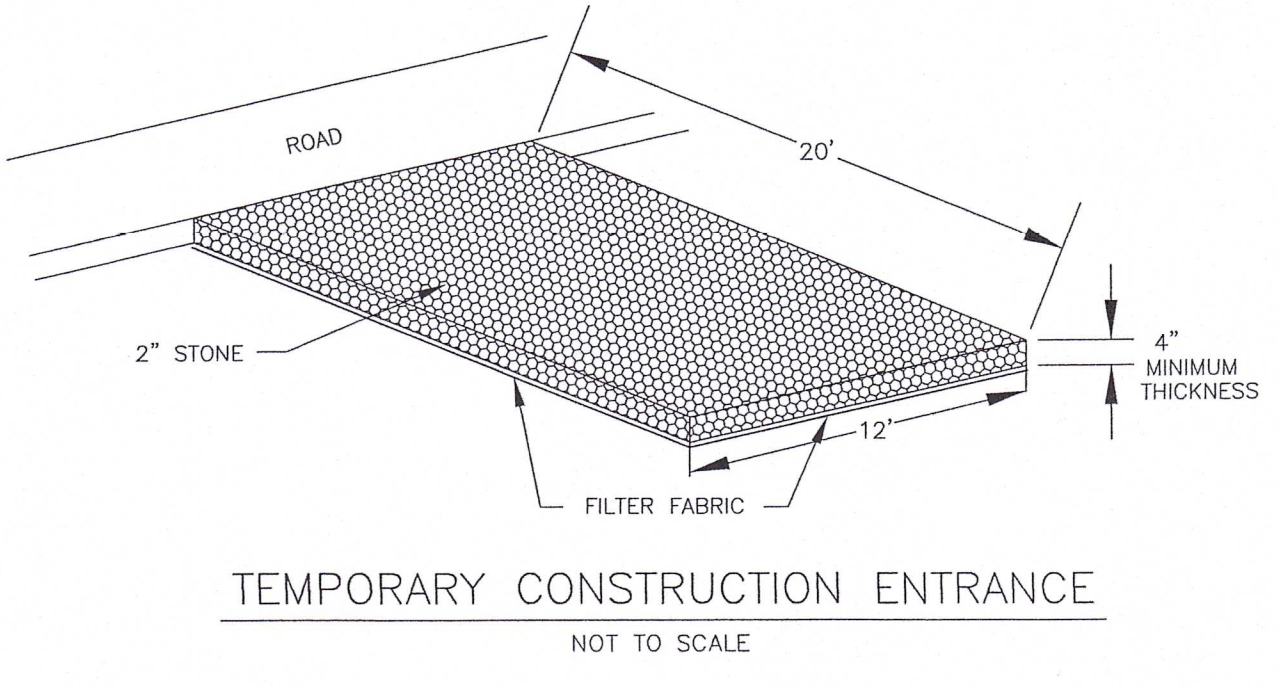
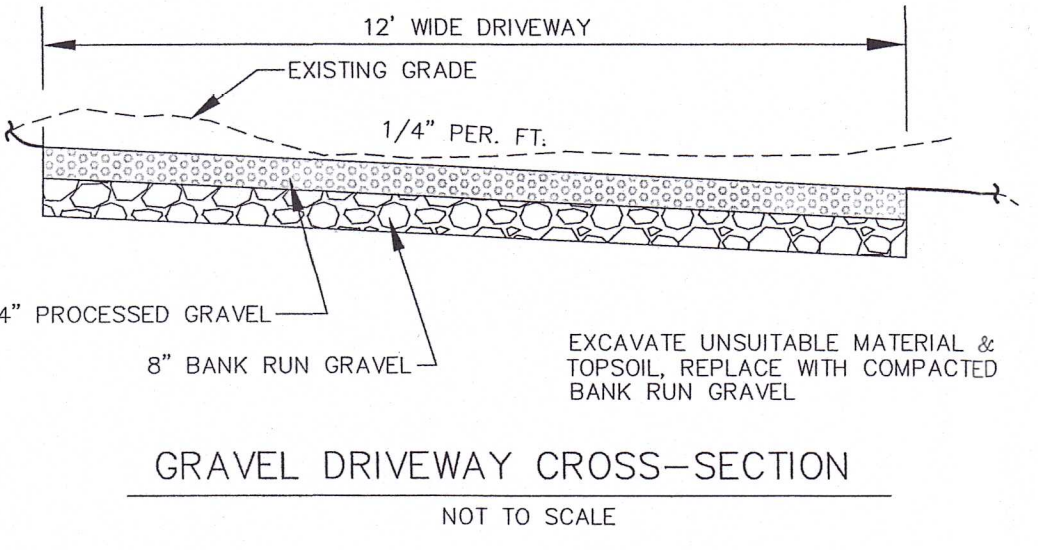
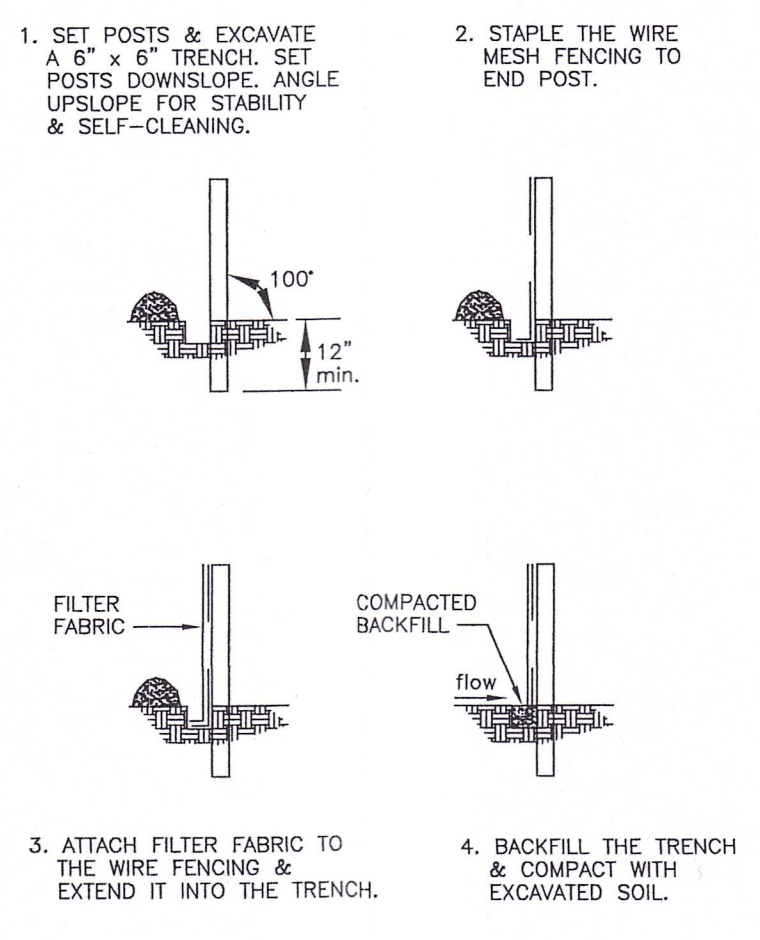

LEGEND

- STREET LINE
PROPERTY LINE
EXISTING CONTOUR
PROPOSED CONTOUR
UTILITY POLE
POND EDGE
EDGE OF WETLANDS & FLAG NUMBER
SILTFENCE

FILTER FABRIC SEDIMENT BARRIER NOT TO SCALE

GRAVEL DRIVEWAY CROSS-SECTION NOT TO SCALE

TEMPORARY CONSTRUCTION ENTRANCE NOT TO SCALE

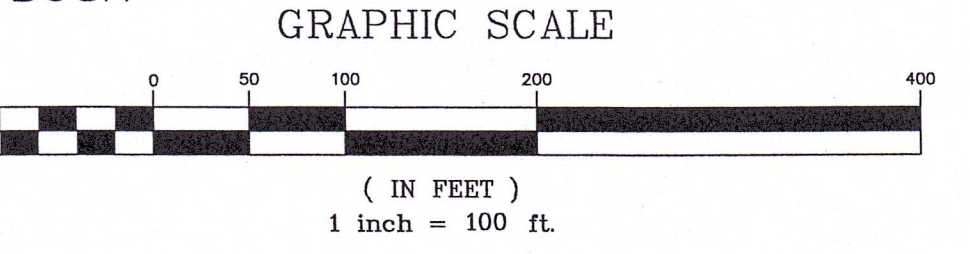

PLAN PREPARED FOR THE TOWN OF LEDYARD LANTERN HILL VALLEY PARK 596-602 LANTERN HILL ROAD LEDYARD, CONNECTICUT SCALES AS SHOWN FEBRUARY 2025

RECEIVED FEB 26 2025 Land Use Department

NOTE: BOUNDARY LINES OF ADJOINING PROPERTIES ARE SHOWN FOR GENERAL INFORMATIONAL PURPOSES ONLY AND ARE NOT TO BE CONSTRUED AS BEING ACCURATELY LOCATED OR DEPICTED.

I HAVE REVIEWED THE INLAND WETLAND BOUNDARY I DELINEATED AND I AM OF THE OPINION THAT THE WETLAND BOUNDARY IS SHOWN CORRECTLY ON THIS MAP.

APPROVED BY THE LEDYARD WETLANDS COMMISSION.

CHAIRMAN LEDYARD INLAND WETLANDS AND WATERCOURSES COMMISSION DATE

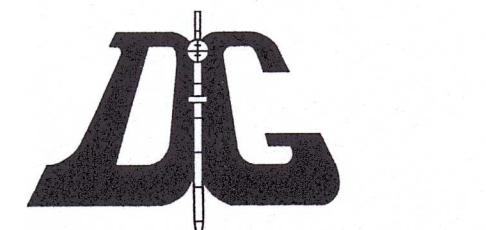

DIETER & GARDNER LAND SURVEYORS • PLANNERS 1641 ROUTE 12 P.O. BOX 335 GALES FERRY, CT. 06335 (860) 464-7455 EMAIL: DIETER.GARDNER@YAHOO.COM

THIS DRAWING IS THE PROPERTY OF THE LAND SURVEYOR. THIS PLAN AND REPRODUCTIONS, ADDITIONS OR REVISIONS OF THIS PLAN ARE NOT VALID WITHOUT THE EMBOSSED SEAL AND SIGNATURE OF THE LAND SURVEYOR WHO PREPARED THIS PLAN. JOB# 22-047.DWG FBK#317

Signature of Ian Cole, Soil Scientist.

THIS MAP AND SURVEY HAS BEEN PREPARED IN ACCORDANCE WITH SECTIONS 20-300B-1 THROUGH 20-300B-20 OF THE REGULATIONS OF CONNECTICUT STATE AGENCIES... MINIMUM STANDARDS OF ACCURACY, CONTENT AND CERTIFICATION FOR SURVEYS AND MAPS IN THE STATE OF CONNECTICUT, ADOPTED EFFECTIVE JUNE 21, 1996, REVISED OCTOBER 26, 2018. IT IS A BOUNDARY SURVEY BASED ON A DEPENDENT RESURVEY CONFORMING TO HORIZONTAL ACCURACY CLASS A-2 AND TOPOGRAPHIC ACCURACY 1-2. TO MY KNOWLEDGE AND BELIEF, THIS MAP IS SUBSTANTIALLY CORRECT AS NOTED HEREON.

TITLE: LAND SURVEYOR CT No. 14208 DATE: FEBRUARY 5, 2025

FDH4

PRELIMINARY DRAWING – NOT FOR CONSTRUCTION

THIS PRINT IS THE PROPERTY OF RCP SHELTERS AND IS NOT TO BE USED, COPIED, OR REPRODUCED WITHOUT THEIR EXPRESSED WRITTEN PERMISSION.

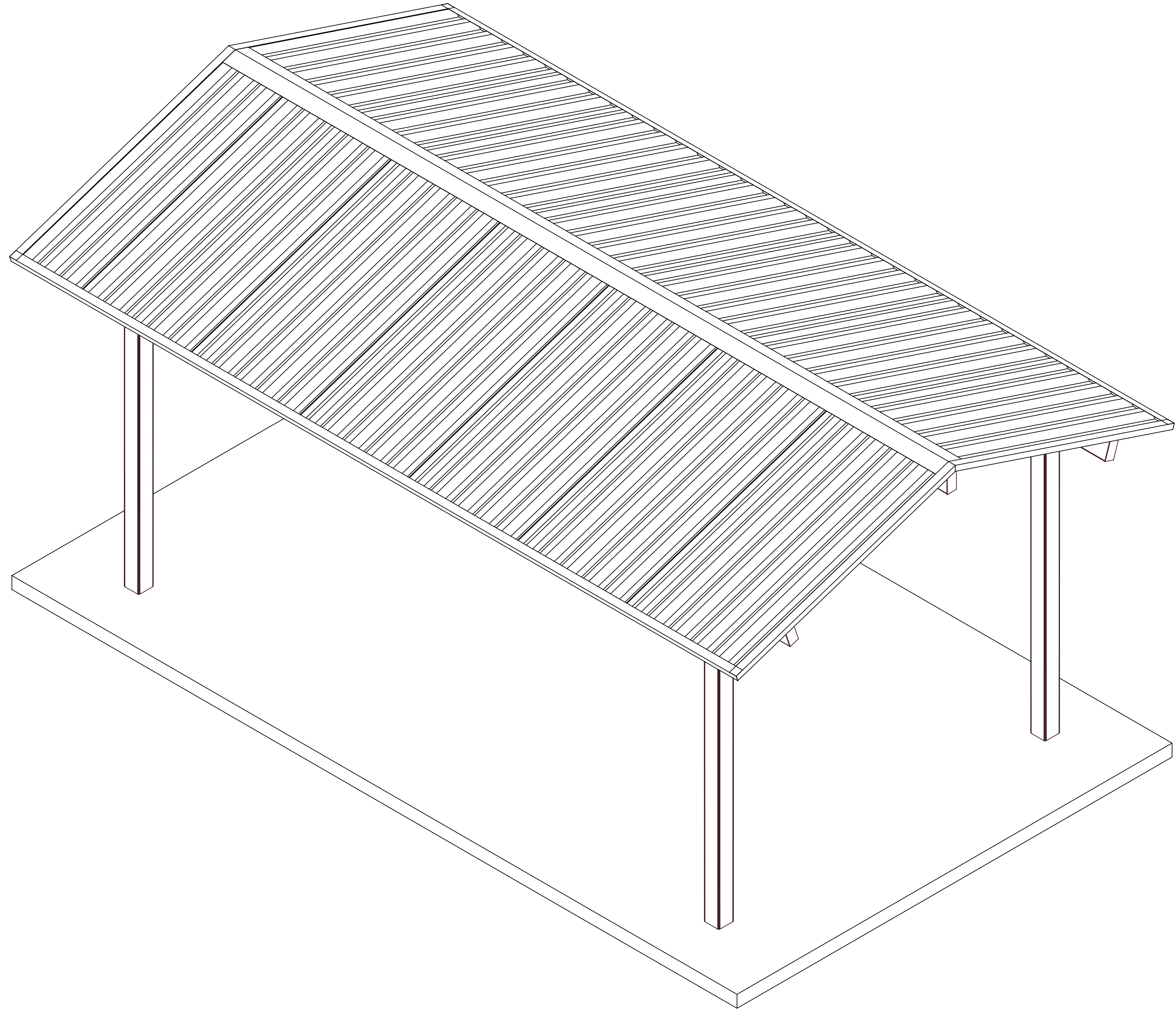
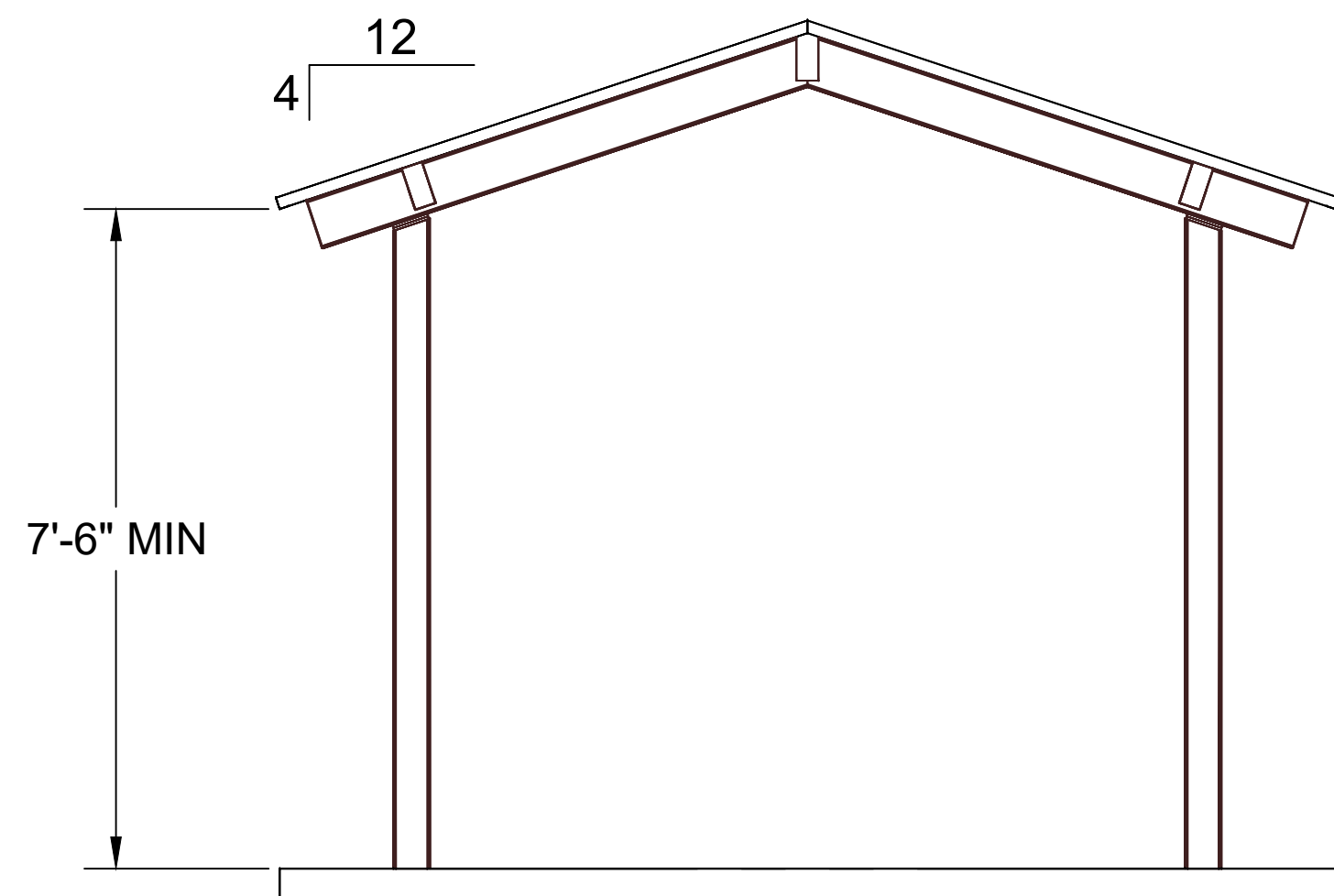
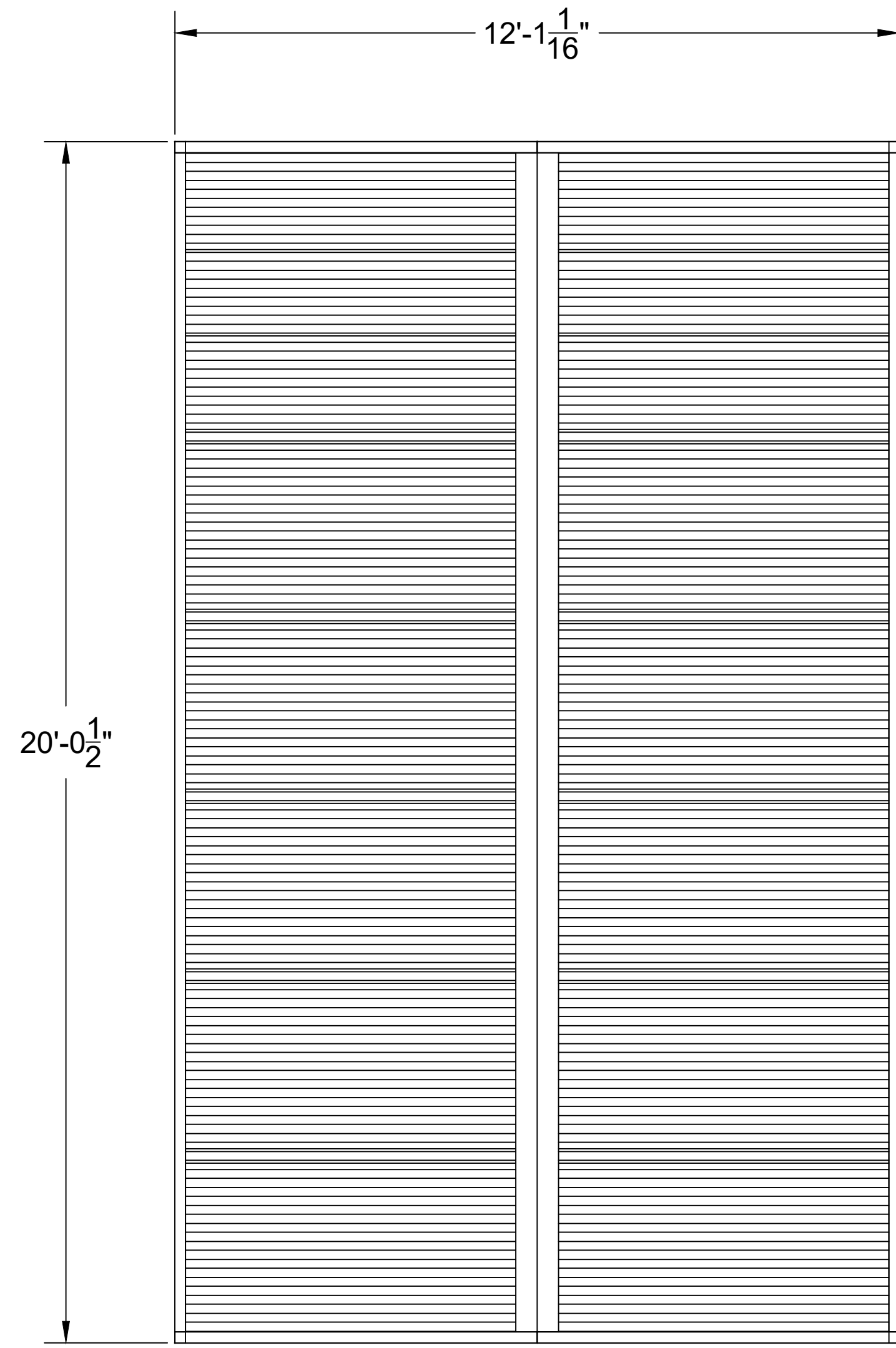

TS-G1220-04

**RCP SHELTERS, INC.**  
 2100 SE RAYS WAY STUART, FL 34994 PO BOX 25 STUART, FL 34995-0025  
 ■ SHELTERS ■ PAVILIONS ■ CONCESSIONS ■ KIOSKS ■ FABRIC SHADE  
 ■ RESTROOMS ■ BANDSHELLS ■ MINI-SHELTERS ■ DUGOUTS ■ FABRIC SAIL  
 Phone 800-525-0207 Fax 772-288-0207  
 www.rcpselters.com Email info@rcpselters.com

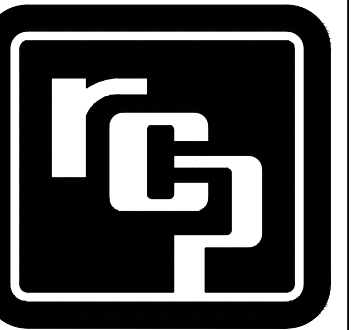

PROJ. NO.:

DRAWN:

CHKD:

REV 1:

REV 2:

REV 3:

REV 4:

REV 5:

CAD NO.:

ECC JOB NO.:

SHEET NO.:

PRELIMINARY DRAWING – NOT FOR CONSTRUCTION

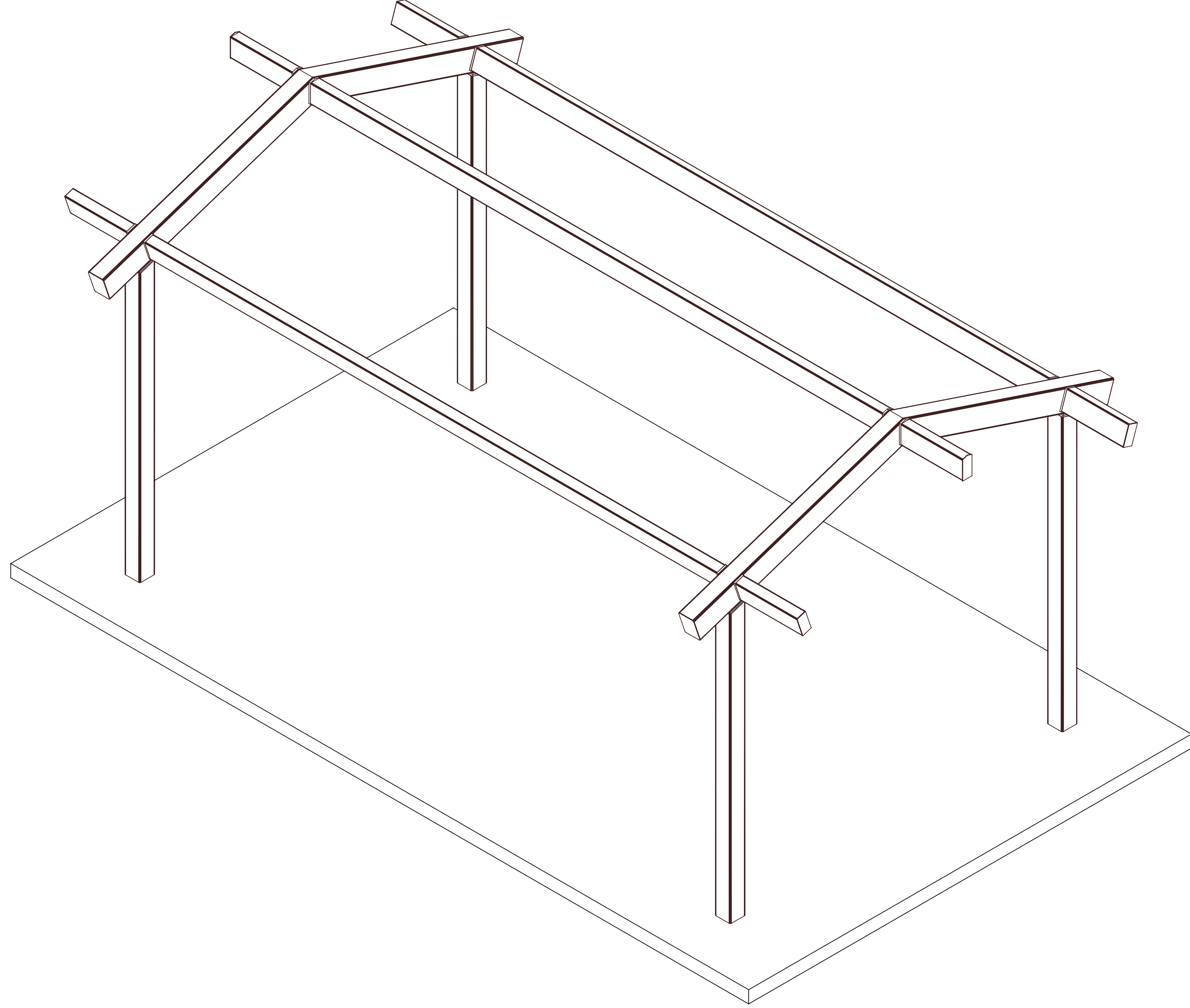
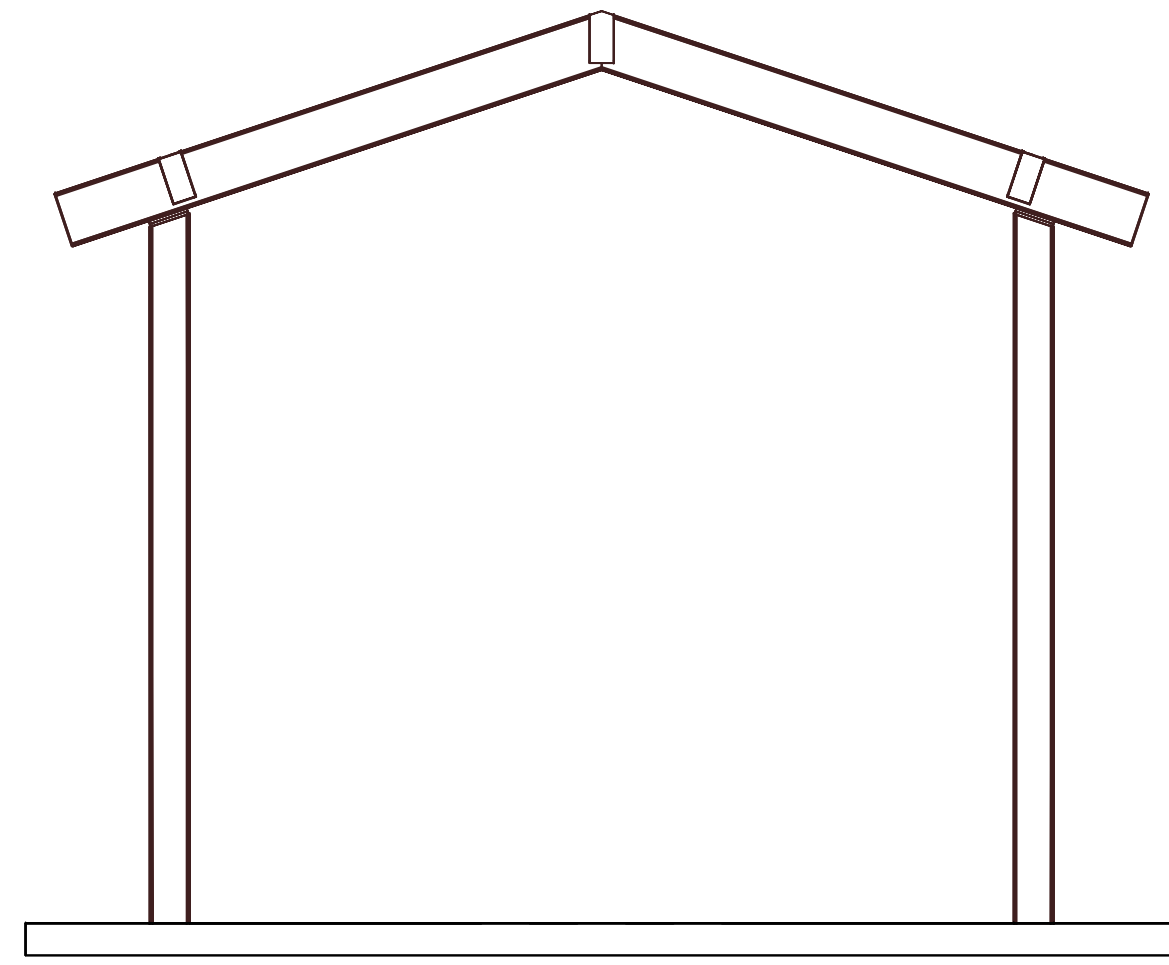
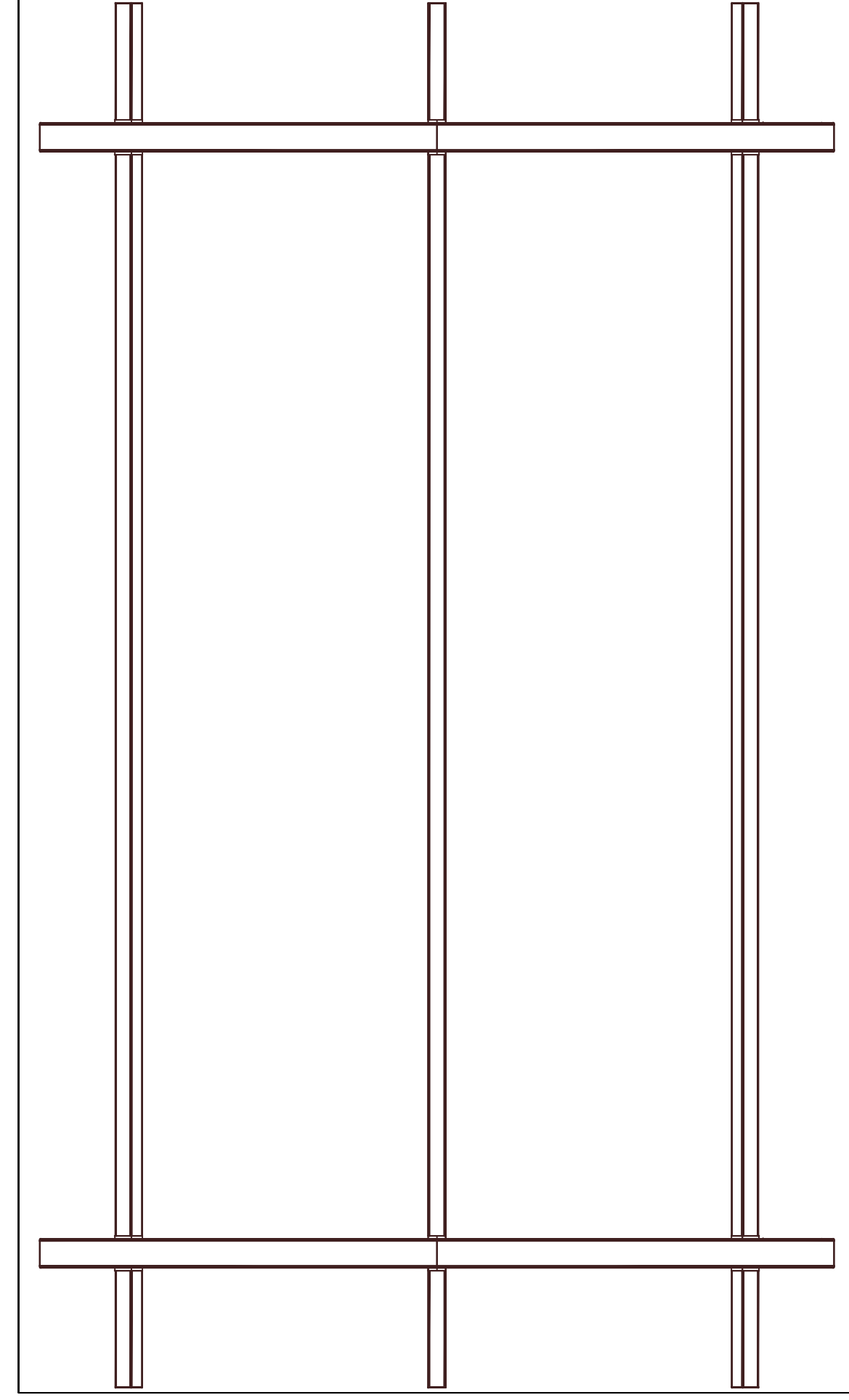

THIS PRINT IS THE PROPERTY OF RCP SHELTERS AND IS NOT TO BE USED, COPIED, OR REPRODUCED WITHOUT THEIR EXPRESSED WRITTEN PERMISSION.

TS-G1220-04

NUMBER OF PURLINS MAY VARY DEPENDING UPON DESIGN LOADS. SIZES AND SPACING OF PURLINS TO BE DETERMINED DURING FINAL DESIGN.

RCP SHELTERS, INC.

2100 SE RAYS WAY STUART, FL 34994 PO BOX 25 STUART, FL 34985-0025

- SHELTERS ■ PAVILIONS ■ CONCESSIONS ■ KIOSKS ■ FABRIC SHADE
- RESTROOMS ■ BANDSHELLS ■ MINI-SHELTERS ■ DUGOUTS ■ FABRIC SAIL

Phone 800-525-0207 Fax 772-288-0207

www.rcpselters.com Email info@rcpselters.com

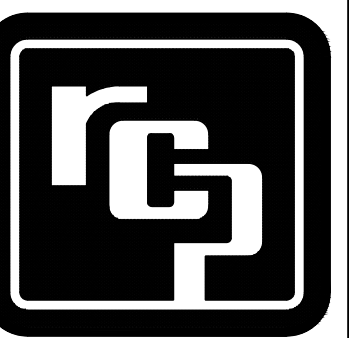

PROJ. NO.:

DRAWN:

CHKD:

REV 1:

REV 2:

REV 3:

REV 4:

REV 5:

CAD NO.:

ECC JOB NO.:

SHEET NO.:

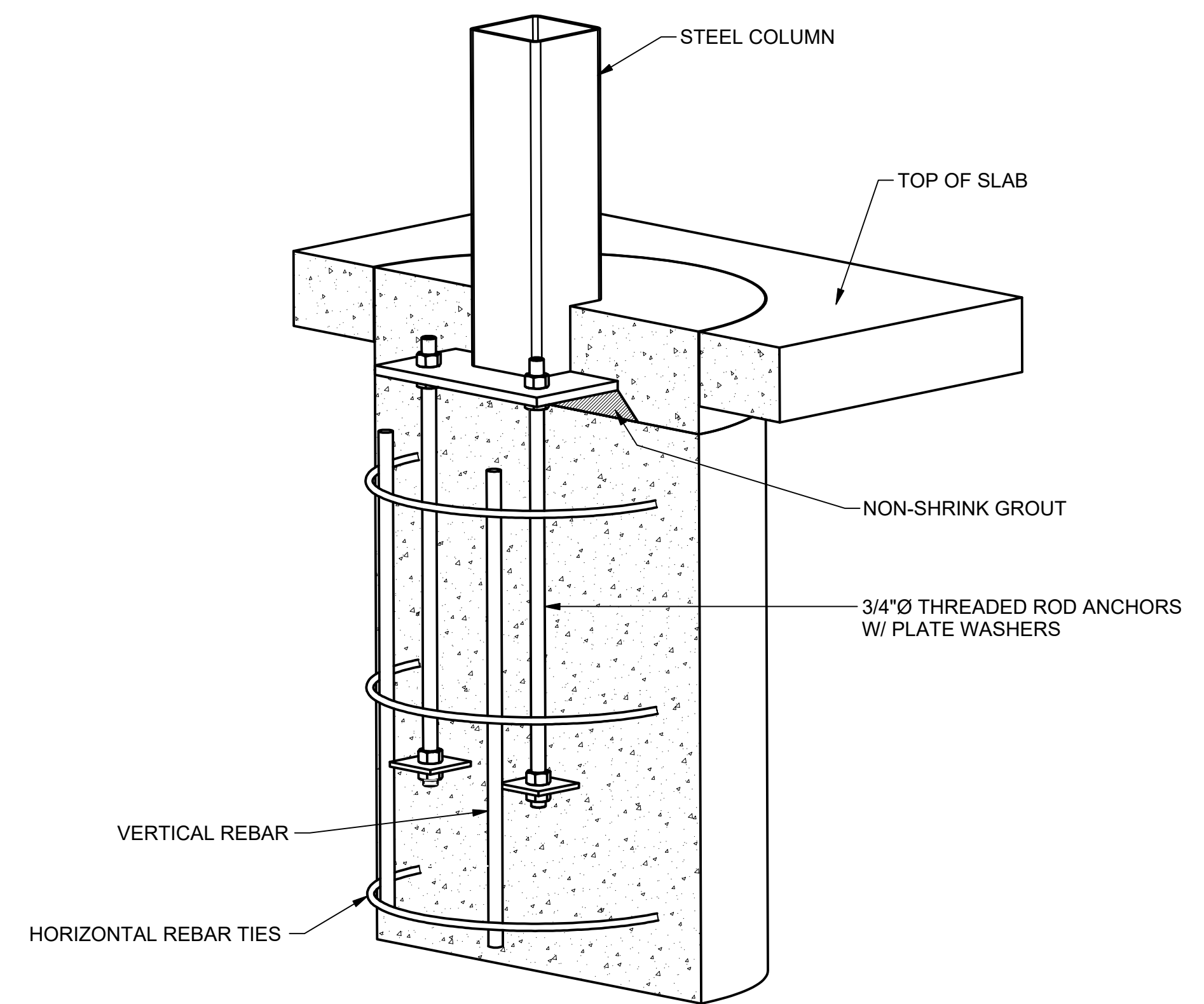
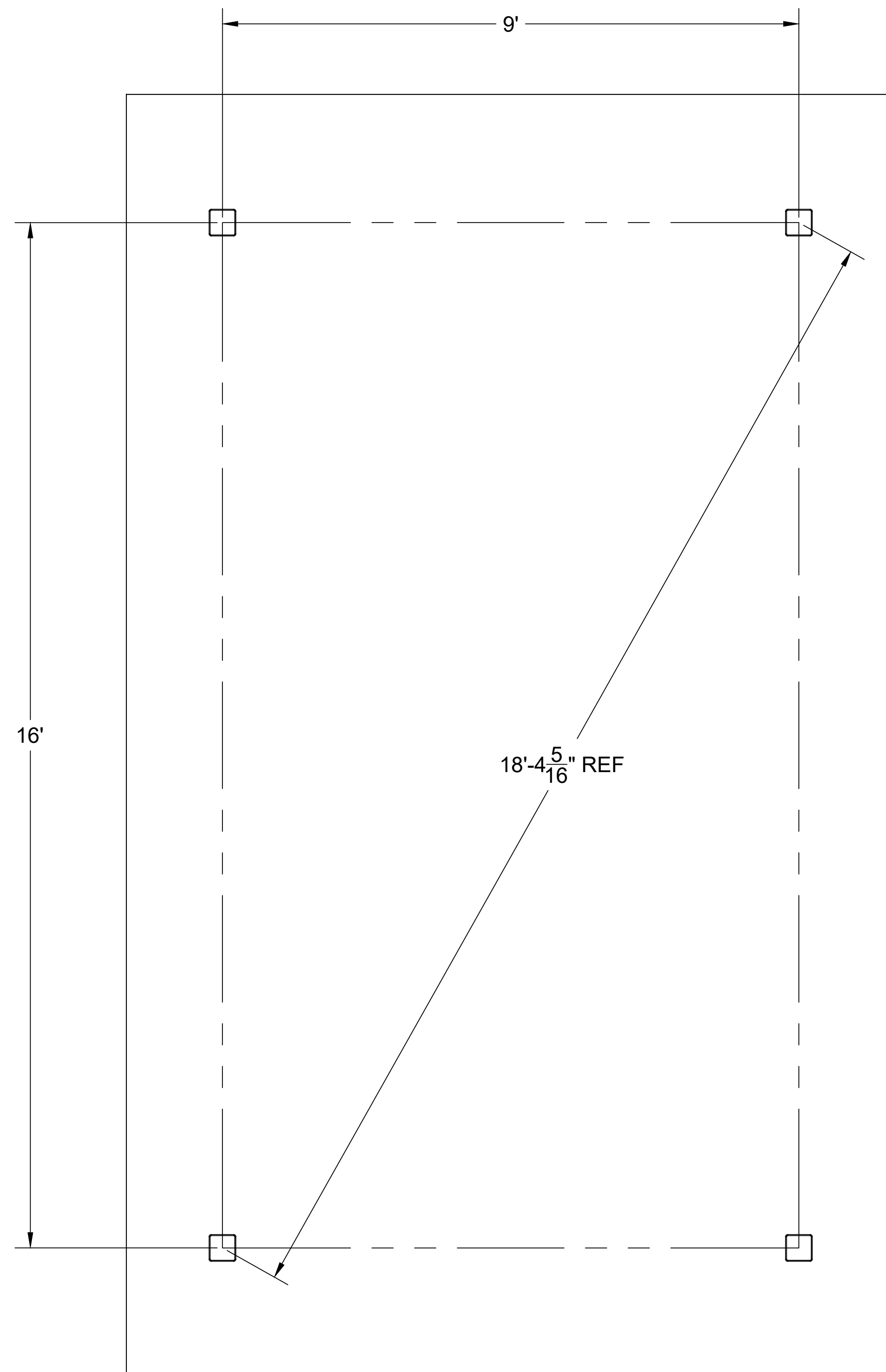

**STEEL COLUMN PIER DETAIL**

TYPICAL PIER DIAMETER IS BETWEEN 2'-0" AND 3'-0"±  
 TYPICAL PIER DEPTH IS BETWEEN 3'-6" AND 5'-6"±

ACTUAL DESIGN WILL VARY DUE TO BUILDING CODE  
 REQUIREMENTS AND MAY BE SUBSTANTIALLY LARGER.

TS-G1220-04

NUMBER OF PURLINS MAY VARY DEPENDING UPON DESIGN LOADS. SIZES AND SPACING OF PURLINS TO BE DETERMINED DURING FINAL DESIGN.

**RCP SHELTERS, INC.**

2100 SE RAYS WAY STUART, FL 34994 PO BOX 25 STUART, FL 34985-0025  
 ■ SHELTERS ■ PAVILIONS ■ CONCESSIONS ■ KIOSKS ■ FABRIC SHADE  
 ■ RESTROOMS ■ BANDSHELLS ■ MINI-SHELTERS ■ DUGOUTS ■ FABRIC SAIL  
 Phone 800-525-0207 Fax 772-288-0207  
 www.rcpselters.com Email info@rcpselters.com

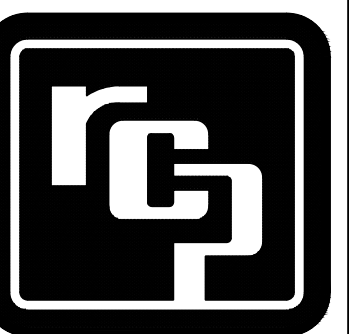

PROJ. NO.:

DRAWN:

CHKD:

REV 1:

REV 2:

REV 3:

REV 4:

REV 5:

CAD NO.:

ECC JOB NO.:

SHEET NO.:

PRELIMINARY DRAWING – NOT FOR CONSTRUCTION



THIS PRINT IS THE PROPERTY OF RCP SHELTERS AND IS NOT TO BE USED, COPIED, OR REPRODUCED WITHOUT THEIR EXPRESSED WRITTEN PERMISSION.

TS-G1220-04

NUMBER OF PURLINS MAY VARY DEPENDING UPON DESIGN LOADS. SIZES AND SPACING OF PURLINS TO BE DETERMINED DURING FINAL DESIGN.

RCP SHELTERS, INC.

2100 SE RAYS WAY STUART, FL 34994 PO BOX 25 STUART, FL 34985-0025

- SHELTERS ■ PAVILIONS ■ CONCESSIONS ■ KIOSKS ■ FABRIC SHADE
- RESTROOMS ■ BANDSHELLS ■ MINI-SHELTERS ■ DUGOUTS ■ FABRIC SAIL

Phone 800-525-0207 Fax 772-288-0207

www.rcpselters.com Email info@rcpselters.com

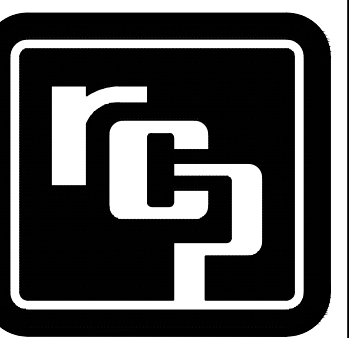

PROJ. NO.:

DRAWN:

CHKD:

REV 1:

REV 2:

REV 3:

REV 4:

REV 5:

CAD NO.:

ECC JOB NO.:

SHEET NO.:

Janet Barnett 3/14/34 - 9/18/24

Thank you for allowing me take a few minutes of your time.

And thank you all for your time and commitment to this Committee.

#### Introduction

I'm here to present a proposal requesting a plaque be installed at the LHV Park Pavilion on Lantern Hill Road in Ledyard to honor Janet Barnett - a lifelong Ledyard resident and strong community advocate.

The JB Memorial Grant was created by monies she left after her passing last year to create and support projects that enhance community spaces. I applied for and was awarded \$5,000 to support the park and recognize JB. The pavilion will provide a gathering space for community and family events, educational programs, and outdoor recreation - all which reflect who she was.

- JB was born and raised in Ledyard, attended the Geer Hill one room school house for her grade school, which she then went on to host many of Ledyard's 5<sup>th</sup> graders for their history series field trips.
- She was a teacher at NFA - taught child development and Sociology for 27 years, and founded and directed a program to support teen mothers and their infants at NFA.
- She was deeply involved as a 4-H club leader to many age groups and genders for over 50 years in Ledyard, served as a local fair officer, and 4-H County Agent. She was involved as an exhibition judge for many years for the Ledyard Fair.
- She ran a Boys summer camp for years on Long Pond, and she supported her husband's Boy Scout Troops as a Scout mom helping many young men go on to become Eagle Scouts.
- She hosted many international foreign exchange students at her home through American Field Service and hosted inner city children for summers through the Fresh Air Fund.
- She was a lifelong member in the Ledyard Congregational Church, serving as a Deacon, on the Missions committee, and organized monthly community potluck dinners.
- She volunteered for years at the now named Linda Davis Food Pantry
- And at the Bill Library she founded and coordinated for several years the Amistad program, which was an after-school tutoring and homework assistance program for multi-language students – and recruited middle school and high school students to be tutors for this program.
- Living in Ledyard meant that she herself participated in many of the Ledyard Parks and Rec programs as did her 6 athletic children.

Her gift was her ability to bring people together which I can imagine mirrors the mission of this very Board. She was rooted in Ledyard, and was dedicated to helping those in need but also mentoring them to build stronger community relationships.

The large Holdridge pavilion in Ledyard Center, is named after her father Paul Holdridge who also was a very active member of our town, another reason I thought this project was fitting for her memory.

The LHV park area and Long Pond - Bush Pond were an important part of her life. This pavilion project sparked my interest in that it encompasses her love of bringing the community together but it's also just a short paddle away on Long Pond over to her family cottage that's been a part of her life since the 1940's.

The 5k will contribute to the new structure, other park amenities, or extra costs and represents a collaborative interest in our public spaces.

The plaque will recognize JB's legacy and her community service, build transparency in how grant funding is used, and could encourage future donations and volunteer engagement

I'm suggesting a plaque which could say "Pavilion funded in part by the JB Memorial Grant, honoring her dedication to the community" be installed somewhere on the pavilion to serve as a meaningful acknowledgment of community support.

I understand that this decision will need to be discussed and approved by this committee and may require additional approvals which I will gladly present.

The new LHV park is being constructed on land generously donated by Bob and Betsy Graham. I've spoken to them regarding this idea to which they are in complete agreement and happily support.

Thank you for your time.

Sandra Fedors  
25 Homestead Road  
Ledyard, CT 06339  
[sfedorsRN@gmail.com](mailto:sfedorsRN@gmail.com)  
860-917-5563

Other dedicated sites in Ledyard Center:

Don Griese Sports Complex

Brad Roberts Field

Pete Olson Tennis courts

Depta Field

DeMuria Pavilion

Mary McGrattan Parklet

Linda Davis Food Pantry

Paul Holdridge Pavilion

Ray Holdridge Circle

Bob Donovan Way



# TOWN OF LEDYARD

741 Colonel Ledyard  
Highway  
Ledyard, CT 06339-1511

---

**File #:** 26-0587

**Agenda Date:** 5/27/2026

**Agenda #:** 3.

---

AGENDA REQUEST  
GENERAL DISCUSSION ITEM

**Subject:**

MOTION to endorse the Parks, Recreation & Senior Citizens Commission proposal to dedicate the Senior Center Fitness Room in Paula Crocker (Paula Crocker Fitness Center).

**Background:**

(type text here)

**Department Comment/Recommendation:**

(type text here)



---

**File #:** 26-0615

**Agenda Date:** 5/27/2026

**Agenda #:** 4.

---

## APPOINTMENT

### **Motion/Request:**

MOTION to recommend the Town Council appoint the following Members to the “*Ad Hoc Committee to Evaluate the Separation of the Planning Commission & Zoning Commission*” a for six-month term in accordance with Res#002-2026/Mar 25

- ***One Member from the Community-at-Large with Planning experience:***  
Mr. Tony Capon (D) 37 Silas Deane Road, Ledyard
- ***One Member from the Community-at-Large with Zoning experience***  
Mr. Kevin Dombrowski ( R) 139 Meetinghouse Lane, Ledyard
- ***One Member from the Planning & Zoning Commission***  
Ms. Beth Ribe (U) 129 Rose Hill Road, Ledyard
- ***One Member from the Community-at-Large***  
Mr. Milton (Dave) Schroder, Jr., (U) 290 Whalehead Road, Gales Ferry
- One Member from the Town Council )

### **Background:**

In response to residents’ request for the Town Council to evaluate whether the Planning and Zoning Commission should remain as a combined Commission; or whether it should be two separate Commissions, at their March 25, 2026 meeting the Town Council adopted a “*Resolution to Establishing an Ad-Hoc Committee to Evaluate the Separation of the Planning Commission & Zoning Commission*”.

### **Administrative Notes:**

#### **Administration Committee Meeting 5/13/2026:**

Councilor Garcia-Irizarry stated the Town Council received eight Appointment Applications from residents interested in serving on the newly established "Ad Hoc Committee to Evaluate the Separation of the Planning Commission & Zoning Commission". However, she stated that the Committee was only calling for a total of four members with specific qualifications; plus one member from the Town Council for a total of five members.

The Administration Committee agreed to review each of the following Applications and to narrow down the

selection for the Motion:

Members to the “Ad Hoc Committee to Evaluate the Separation of the Planning Commission & Zoning Commission” a for six-month term in accordance with Res#002-2026/Mar 25

· One Member from the Community-at-Large with Planning experience:

Mr. Michael Cherry (U) 5 Whippoorwill Drive, Gales Ferry

\*Mr. Tony Capon (D) 37 Silas Deane Road, Ledyard

Mr. Jeffrey Kulo (D) 39 Chriswood Trace, Ledyard

· One Member from the Community-at-Large with Zoning experience

\*Mr. Kevin Dombrowski ( R) 139 Meetinghouse Lane, Ledyard

Mr. Eric Treaster, ( R)10 Huntington Way, Ledyard

Mr. Michael Cherry (U) 5 Whippoorwill Drive, Gales Ferry

Mr. Tony Capon (D) 37 Silas Deane Road, Ledyard

Mr. Jeffrey Kulo (D) 39 Chriswood Trace, Ledyard

· One Member from the Planning & Zoning Commission

\*Ms. Beth Ribe (U) 129 Rose Hill Road, Ledyard

· One Member from the Community-at-Large

\*Mr. Milton (Dave) Schroeder, Jr., (U) 290 Whalehead Road, Gales Ferry

Mr. Edwin Murray ( R) 26 Deveonshire Drive, Gales Ferry

· One Member from the Town Council )

The Administration Committee commented on the difficulty to only select four members, noting that each of Candidates had extensive qualifications and experience. By consensus the Administration Committee to forward the Applications as noted with an asterisk above.

### **Nominating Committee Recommendation:**

(type text here)

### **Minority Representation - CGS 9-167a:**

In accordance with Chapter IV; Section 8 of the Town Charter “Except as otherwise provided for in this Charter, the Town Council may appoint members to fill vacancies in other offices, boards, and commissions established by this Charter and by ordinance as vacancies may occur, and appointing members to such offices, boards, and commissions as may be created in the future. Such appointments shall be made by the Town Council for such terms and upon such conditions as provided in the respective ordinance”.

Chapter IV, Section 9: “In making appointments and removals, the Town Council shall act by the affirmative votes of at least a majority of all its members.

All members of boards, commissions, and committees contained in this Charter, or subsequently created under

this Charter, except members of the Building Code Board of Appeals, the Fire Marshal, and the Deputy Fire Marshal(s), shall be electors of the Town at the time of their appointment and during their terms of office.”

**Connecticut General Statutes**

Sec. 9-167a. Minority representation. (a) (1) Except as provided in subdivision (2) of this subsection, the maximum number of members of any board, commission, legislative body, committee or similar body of the state or any political subdivision thereof, whether elective or appointive, who may be members of the same political party, shall be as specified in the following table:

Total Membership	Maximum from One Party
3	2
4	3
5	4
6	4
7	5
8	5
9	6
More than 9 Two-thirds of total membership	

(2) The provisions of this section shall not apply (A) to any such board, commission, committee or body whose members are elected wholly or partially on the basis of a geographical division of the state or political subdivision, (B) to a legislative body of a municipality (i) having a town meeting as its legislative body or (ii) for which the charter or a special act, on January 1, 1987, provided otherwise or (C) to the city council of an unconsolidated city within a town and the town council of such town if the town has a town council and a representative town meeting, the town charter provides for some form of minority representation in the election of members of the representative town meeting, and the city has a city council and a body having the attributes of a town meeting or (D) to the board of directors and other officers of any district, as defined in section 7-324, having annual receipts from all sources not in excess of two hundred fifty Thousand dollars.

(b) Prior to any election for or appointment to any such body, the municipal clerk, in cases of elections, and the appointing authority, in cases of appointments, shall determine the maximum number of members of any political party who may be elected or appointed to such body at such election or appointment. Such maximum number shall be determined for each political party in the following manner: From the number of members of one political party who are members of such body at the time of the election or appointment, subtract the number of members of such political party whose terms expire prior to the commencement of the terms for which such election or appointment is being held or made and subtract the balance thus arrived at from the appropriate number specified in column II of subsection (a) of this section.

**Application Form****Profile**

Michael

First Name

J

Middle  
Initial

Cherry

Last Name

mj.cherry@comcast.net

Email Address

5 Whippoorwill Drive

Home Address

Suite or Apt

Gales Ferry

City

CT

State

06335

Postal Code

Home: (860) 464-7886

Primary Phone

Mobile: (860) 460-3546

Alternate Phone

**Which Boards would you like to apply for?**

Ad Hoc Committee to Evaluate the Separation of the Planning Commission & Zoning Commission: Submitted

**Education & Experiences**

Please tell us about yourself and why you want to serve.

**Why are you interested in serving on a board or commission?**

I possess Extensive Knowledge and experience in Land Use Boards and Commissions including their functions and operation. My unique experience would be most valuable to discern the feasibility, benefits, and costs of separating the Planning and Zoning Commission into two separate entities. I am well versed in the roles and possess the tools to evaluate whether separation would increase efficiency; improve public transparency, and reduce the potential for conflicts of interest. I possess in depth knowledge and experience to review and evaluate staffing impacts, budgetary implications, modifications to department organization, changes required to local ordinances including the Town of Ledyard Charter, and potential improvements to the permitting timeline.

**Community Involvement**

Previous member and chair of the Ledyard Planning Commission and Ledyard Planning and Zoning Commission. Current member and previous member and chair of the Ledyard Economic Development Commission. Previous member and chair of the Ledyard WPCA. Previous member and chair of the SECOG Regional Planning Commission. Former employment as interim Ledyard Zoning Enforcement Official

**Educational Background**

Graduate engineer, Retired Naval Nuclear Officer, Retired Electric Boat Manager Completed UCONN CLEAR Land Use Training for Commissioners Completed UCONN CLEAR Land Use Commissioner Advanced Training Participated in Biennial CT Bar Land Use Seminars Participated in numerous workshops on Land Use Issues over the years of serving

Michael J Cherry

Retired

Employer

Job Title

Upload a Resume

---

## Party Affiliation

### Party Affiliation \*

Unaffiliated

---

## Disclaimer & FOIA Information

Your attendance and active participation is important for the Committee to conduct its business. Any member of a Committee/Commission/Board who is absent from three (3) consecutive regular meetings and any intervening duly called special meetings shall be considered to have resigned from the Committee and the vacancy shall be filled, except that the Committee may vote to waive attendance requirements in each case where illness or other extenuating circumstances make it impossible for a member to meet the attendance requirements. It shall be the responsibility of the Chairman of the Committee to notify the Town Council or Mayor's office when a member has not properly performed his/her duties.

### Please Agree with the Following Statement

**If selected as a board member, I understand that information on this application is subject to the Freedom of Information Act (FOIA) and may be disclosed to anyone requesting this information.**

I Agree

### Signature (type full name below)

Michael J Cherry

**Roxanne Maher**

---

**From:** mj.cherry@comcast.net  
**Sent:** Wednesday, February 11, 2026 12:21 PM  
**To:** Roxanne Maher  
**Subject:** formation of an Ad-Hoc Committee to evaluate if the Planning & Zoning Commission should stay as one commission or if it should be separated into two Commissions.

Please forward to Admin Committee

As a former member and Chair of the Ledyard Planning Commission and former member and Chair of the combined PZC I would be eminently qualified and pleased to serve on any Ad-Hoc committee formed to study the subject question.

Thank You for your consideration.

M. J. Cherry  
mj.cherry@comcast.net  
(860) 460-3546

**Application Form****Profile**

Tony

First Name

Capon

Last Name

Middle  
Initial

tcapon@pitt.edu

Email Address

37 Silas Deane Road

Home Address

Suite or Apt

Ledyard

City

CT  
State

06339

Postal Code

Home: (860) 381-5098

Primary Phone

Mobile: (814) 934-9067

Alternate Phone

**Which Boards would you like to apply for?**

Ad Hoc Committee to Evaluate the Separation of the Planning Commission & Zoning Commission: Submitted

**Education & Experiences**

Please tell us about yourself and why you want to serve.

**Why are you interested in serving on a board or commission?**

I am a 38 year resident of Ledyard -- 1947-1969 and 2010 - present. I have knowledge and experience with planning and zoning and understand how the two functions are integrated. I am the immediate past chairman of PZC (2021-2024) and have served on ZBA and IWWC. I have been on WPCA for twelve years. WPCA is involved in the planning and zoning process since the provision of public water and sewer is critical to development, especially in Ledyard Center. I am a research methodologist and statistician by background and education and in my professional career have been involved in program evaluation. I have a total of about 40 years experience as a parliamentarian and am pretty good at keeping meetings on track.

**Community Involvement**

I chaired Ledyard's 175th celebration committee. I am a volunteer income tax preparer. I am a United Way volunteer. I am a member of the Ledyard Avalonia Town Committee. Over my life I served on a number of community boards.

**Educational Background**

B.A. Holy Cross, 1969 M.A. University of Virginia, 1974 PhD University of Virginia, 1976.

Retired

Employer

Job Title

---

**Party Affiliation**

**Party Affiliation \***

Democrat

---

**Disclaimer & FOIA Information**

Your attendance and active participation is important for the Committee to conduct its business. Any member of a Committee/Commission/Board who is absent from three (3) consecutive regular meetings and any intervening duly called special meetings shall be considered to have resigned from the Committee and the vacancy shall be filled, except that the Committee may vote to waive attendance requirements in each case where illness or other extenuating circumstances make it impossible for a member to meet the attendance requirements. It shall be the responsibility of the Chairman of the Committee to notify the Town Council or Mayor's office when a member has not properly performed his/her duties.

**Please Agree with the Following Statement**

**If selected as a board member, I understand that information on this application is subject to the Freedom of Information Act (FOIA) and may be disclosed to anyone requesting this information.**

I Agree

**Signature (type full name below)**

Tony Capon

Tony Capon  
Brief Resume

Grew up in Ledyard, graduated from NFA in 1965

Graduated from Holy Cross in 1969

Served three years as a naval officer on a destroyer during the Vietnam War

Got a PhD in sociology from the University of Virginia in 1976

Taught at the University of Pittsburgh for 33 years, retired as an Emeritus  
Professor

Moved back to Ledyard in 2010

Taught at ECSU as an Adjunct Professor from 2010 to 2021

## Roxanne Maher

---

**From:** Craig Breverman <cbreverman@gmail.com>  
**Sent:** Wednesday, May 6, 2026 8:15 AM  
**To:** Roxanne Maher  
**Cc:** Wendy Hellekson  
**Subject:** Re: Appoint Applications - DTC Recommendation

Hi Roxanne,  
Thanks for everything, this is what happens to me when I let time slip past me.

We approved Jeff Kulo and Tony Capon to *Ad Hoc Committee to Evaluate The Separation of the Planning Commission & Zoning Commission*.

I'll work on these others today.

On Mon, May 4, 2026 at 10:51 AM Roxanne Maher <[council@ledyardct.org](mailto:council@ledyardct.org)> wrote:

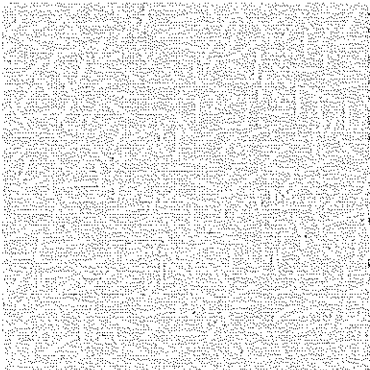

Good Morning Craig:

Please find attached the following Appointment Applications for the  
DTC to provide a recommendation:

- Gary Schneider – Ad Hoc Committee – Develop Process for Capital Improvement Projects
- Jermey Norris – Famers Market Cmt

**Roxanne Maher**

---

**From:** Roxanne Maher  
**Sent:** Tuesday, March 31, 2026 2:51 PM  
**To:** Craig Breverman  
**Cc:** Roxanne Maher; Wendy Hellekson  
**Subject:** Appointment Application - Capon-  
**Attachments:** Appointment Application-Capon-Resume-Evaluate Seperate Planning & Zoning Commission-2026-03-31.pdf; Request Nominations-Committee to Evaluate Seperate Planning Commission & Seperate Zoning Commission- memo-2026-03-26.pdf

Good Afternoon Chairman Braverman:

Please find attached an Appointment Application from Mr. Tony Capon who is interested in the *Ad Hoc Committee to Evaluate The Separation of the Planning Commission & Zoning Commission*” for the DTC to provide an recommendation.

Please let me know if you have any questions or I can be of any assistance.

Thank you,  
Roxanne

*Roxanne M. Maher*  
Administrative Assistant to  
The Ledyard Town Council  
(860) 464-3203  
[council@ledyardct.org](mailto:council@ledyardct.org)

Town Hall Hours:  
Monday – Thursday 7:45 a.m. – 4:45 p.m.  
Closed on Friday



**Roxanne Maher**

---

**From:** Roxanne Maher  
**Sent:** Tuesday, May 5, 2026 2:51 PM  
**To:** Carmen Garcia Irizarry  
**Cc:** Roxanne Maher  
**Subject:** FW: Appoint Application- Mr. Kulo - DTC Recommendation  
**Attachments:** APPOINT APPLICAITON-KULO-EVALUATE SEPERATE PLANNING AND ZONING  
COMMISISON AD HOC CMT.pdf; Request Nominations-Committee to Evaluate Seperate  
Planning Commission & Seperate Zoning Commission- memo-2026-03-26.pdf

---

**From:** Roxanne Maher  
**Sent:** Thursday, April 9, 2026 12:20 PM  
**To:** Craig Breverman <cbreverman@gmail.com>  
**Cc:** Wendy Hellekson <whellekson.dtc@gmail.com>; Roxanne Maher <council@ledyardct.org>  
**Subject:** Appoint Application- Mr. Kulo - DTC Recommendation

Good Afternoon Chairman Braverman

Please find attached an Appointment Application from Mr. Jeff Kulo who is interested in the *Ad Hoc Committee to Evaluate the Separation of the Planning Commission & Zoning Commission* for the DTC to provide a recommendation.

Please let me know if you have any questions or I can be of any assistance.

Thank you,  
Roxanne

*Roxanne M. Maher*  
Administrative Assistant to  
The Ledyard Town Council  
(860) 464-3203  
[council@ledyardct.org](mailto:council@ledyardct.org)

Town Hall Hours:  
Monday – Thursday 7:45 a.m. – 4:45 p.m.  
Closed on Friday

# Application Form

## Profile

Jeffrey \_\_\_\_\_ Kulo \_\_\_\_\_  
First Name Middle Initial Last Name

jkulo@sbcglobal.net \_\_\_\_\_  
Email Address

39 Chriswood Trce \_\_\_\_\_ Suite or Apt \_\_\_\_\_  
Home Address

Ledyard \_\_\_\_\_ CT \_\_\_\_\_ 06339 \_\_\_\_\_  
City State Postal Code

Mobile: (860) 389-7878 \_\_\_\_\_ Home: (860) 464-1181 \_\_\_\_\_  
Primary Phone Alternate Phone

## Which Boards would you like to apply for?

Ad Hoc Committee to Evaluate the Separation of the Planning Commission & Zoning Commission: Submitted

## Education & Experiences

Please tell us about yourself and why you want to serve.

### Why are you interested in serving on a board or commission?

To maintain my community involvement on an organized basis.

## Community Involvement

Served on Planning Commission and then Planning & Zoning Commission for about 10 years total. Served on Commission to evaluate form of town government - 1 year duration. Current member of Ledyard DTC - serving as Treasurer.

## Educational Background

B.S. Mechanical Engineering. Various graduate courses; mostly technical.

Retired \_\_\_\_\_  
Employer Job Title

\_\_\_\_\_  
Upload a Resume

## Party Affiliation

**Party Affiliation \***

---

Democrat

---

**Disclaimer & FOIA Information**

Your attendance and active participation is important for the Committee to conduct its business. Any member of a Committee/Commission/Board who is absent from three (3) consecutive regular meetings and any intervening duly called special meetings shall be considered to have resigned from the Committee and the vacancy shall be filled, except that the Committee may vote to waive attendance requirements in each case where illness or other extenuating circumstances make it impossible for a member to meet the attendance requirements. It shall be the responsibility of the Chairman of the Committee to notify the Town Council or Mayor's office when a member has not properly performed his/her duties.

**Please Agree with the Following Statement**

---

**If selected as a board member, I understand that information on this application is subject to the Freedom of Information Act (FOIA) and may be disclosed to anyone requesting this information.**

---

I Agree

**Signature (type full name below)**

---

Jeffrey Kulo

# Application Form

## Profile

Kevin \_\_\_\_\_ J \_\_\_\_\_ Dombrowski \_\_\_\_\_  
 First Name Middle Initial Last Name

kjdombrowski@comcast.net \_\_\_\_\_  
 Email Address

139 Meetinghouse Lane \_\_\_\_\_ Suite or Apt \_\_\_\_\_  
 Home Address

Ledyard \_\_\_\_\_ CT \_\_\_\_\_ 06339 \_\_\_\_\_  
 City State Postal Code

Home: (860) 536-8274 \_\_\_\_\_ Mobile: (860) 383-6463 \_\_\_\_\_  
 Primary Phone Alternate Phone

## Which Boards would you like to apply for?

Ad Hoc Committee to Evaluate the Separation of the Planning Commission & Zoning Commission: Submitted

## Education & Experiences

Please tell us about yourself and why you want to serve.

### Why are you interested in serving on a board or commission?

Have previously served on the Zoning commission, and are looking to move forward Planning and Zoning in the best interest of the Town

## Community Involvement

Previous member of Zoning Commission, Ledyard Town Center Committee, Economic Development Commission, Zoning Board Of Appeals, Zoning Regulation Rewrite Adhoc Committee, Agricultural Zoning Regulation re-write committee, Charter Review Commission 2018, and Ledyard Town Council

## Educational Background

Associates Degree Electrical Engineering

Electric Boat \_\_\_\_\_ Staff Engineer \_\_\_\_\_  
 Employer Job Title

Upload a Resume \_\_\_\_\_

## Party Affiliation

**Party Affiliation \***

---

Republican

---

**Disclaimer & FOIA Information**

Your attendance and active participation is important for the Committee to conduct its business. Any member of a Committee/Commission/Board who is absent from three (3) consecutive regular meetings and any intervening duly called special meetings shall be considered to have resigned from the Committee and the vacancy shall be filled, except that the Committee may vote to waive attendance requirements in each case where illness or other extenuating circumstances make it impossible for a member to meet the attendance requirements. It shall be the responsibility of the Chairman of the Committee to notify the Town Council or Mayor's office when a member has not properly performed his/her duties.

**Please Agree with the Following Statement**

---

**If selected as a board member, I understand that information on this application is subject to the Freedom of Information Act (FOIA) and may be disclosed to anyone requesting this information.**

---

I Agree

**Signature (type full name below)**

---

Kevin J. Dombrowski

To the Ledyard Town Council,

The Ledyard Republican Town Committee absolutely endorses Kevin Dombrowski for the Ad Hoc Committee to Evaluate the Separation of the Planning Commission & Zoning Commission. He has all the experiences to play a significant roll to assist the committee to work towards a fair and equitable solution.

Joe Gush - RTC Nominating Chairperson

**Application Form****Profile**

Eric Treaster  
 First Name Middle Last Name

bsaofnl-eric@yahoo.com  
 Email Address

10 Huntington Way  
 Home Address Suite or Apt

Ledyard CT 06339  
 City State Postal Code

Home: (860) 536-6240  
 Primary Phone Alternate Phone

**Which Boards would you like to apply for?**

Ad Hoc Committee to Evaluate the Separation of the Planning Commission & Zoning Commission: Submitted

**Education & Experiences**

Please tell us about yourself and why you want to serve.

**Why are you interested in serving on a board or commission?**

I am retired, care, and have the time, ability, knowledge, and interest to contribute to the development of our Town. I appreciate your consideration and am available for an interview at any time.

**Community Involvement**

I was on the Zoning Commission for about 25 years, from September 1987 until the end of 2012, when it combined with the Planning Commission. I was its Chairman from August 2010 to October 2012. I wrote the zoning regulations that led to the development of Stonegate Village, which I believe is Ledyard's 17th-largest taxpayer. I authored the 2012 version of the Zoning Regulations and have maintained an active interest in zoning, property, the protection of property values, and especially land use issues as they apply to quality of life. In November 2015, the Town Council appointed me to the Board of Assessment Appeals, where I continue to serve. In May 2016, the Mayor appointed me to the Zoning Board of Appeals, where I served until December 2025. I authored the Zoning Citation Ordinance and corrected and improved the Blight Citation Ordinance. I also developed the forms and procedures to implement the ordinances. On October 31, 2022, the Mayor appointed me as the zoning citation hearing officer, and on July 26, 2023, he appointed me as the blight citation hearing officer - positions I held until November 20, 2025.

**Educational Background**

BS - Math & Electronic Engineering (Cal Poly, San Luis Obispo, CA) MS - Computer Systems Management (Naval Postgraduate School, Monterey, CA.)

Eric Treaster

Retired

Employer

Engineer - Naval Under  
Water Systems Center; Ship  
Analytics (Consultant)

Job Title

---

 Upload a Resume
 

---



---

## Party Affiliation

### Party Affiliation \*

 Republican
 

---



---

## Disclaimer & FOIA Information

Your attendance and active participation is important for the Committee to conduct its business. Any member of a Committee/Commission/Board who is absent from three (3) consecutive regular meetings and any intervening duly called special meetings shall be considered to have resigned from the Committee and the vacancy shall be filled, except that the Committee may vote to waive attendance requirements in each case where illness or other extenuating circumstances make it impossible for a member to meet the attendance requirements. It shall be the responsibility of the Chairman of the Committee to notify the Town Council or Mayor's office when a member has not properly performed his/her duties.

### Please Agree with the Following Statement

**If selected as a board member, I understand that information on this application is subject to the Freedom of Information Act (FOIA) and may be disclosed to anyone requesting this information.**

---

 I Agree

### Signature (type full name below)

---

 Eric Treaster

To: Admin Committee / Town Council,  
Eric Treaster is a well-informed, and well-versed candidate for a position on the ADHOC Committee for the evaluation of separating the Planning and Zoning Commission. He is a past Chairman of this Committee and understands the processes. The RTC forwards his application for your approval.

Joe Gush  
Ledyard RTC Nominating Committee Chairman

**Roxanne Maher**

---

**From:** Eric <bsaofnl-eric@yahoo.com>  
**Sent:** Monday, March 30, 2026 10:27 AM  
**To:** Town Council Group  
**Cc:** Roxanne Maher  
**Subject:** Request for Membership on the Ad Hoc Committee To Evaluate the Separation of the Planning Commission & Zoning Commission

To: Members of the Town Council

Pursuant to the Council's *"Resolution Establishing An Ad Hoc Committee To Evaluate the Separation of the Planning Commission & Zoning Commission,"* this email is a request to be considered a candidate for either the "Community-at-Large with Zoning Experience" member, or a candidate for the "Community-at-Large" member.

As some of you know, I was on the Zoning Commission for about 25 years, from September 1987 until the end of 2012, when it combined with the Planning Commission. I was its Chairman from August 2010 to October 2012, when the Commission disbanded and combined with the Planning Commission.

I wrote the zoning overlay regulations that led to the development of Stonegate Village, which I believe is Ledyard's 17th-largest taxpayer. I authored the 2012 version of the Zoning Regulations and have maintained an active interest in zoning, property, property values, and land-use issues.

In November 2015, the Town Council appointed me to the Board of Assessment Appeals, where I continue to serve.

In May 2016, the Mayor appointed me to the Zoning Board of Appeals, where I served until my last term expired in December 2025. I authored the Zoning Citation Ordinance and corrected and improved the Blight Citation Ordinance. I also developed the forms and procedures to implement the ordinances.

On October 31, 2022, the Mayor appointed me as the zoning citation hearing officer, and on July 26, 2023, he appointed me as the blight citation hearing officer – positions I held until November 20, 2025.

I am retired, care, and have the time, ability, knowledge, and interest to contribute to the development of our Town.

I appreciate your consideration and am available for an interview at any time.

Respectfully,

Eric Treaster  
860-536-6240



## TOWN OF LEDYARD

### Department of Land Use and Planning

*Elizabeth J. Burdick, Director*

741 Colonel Ledyard Highway, Ledyard, CT 06339

Telephone: (860) 464-3215, Fax: (860) 464-0098

Email: [planner@ledyardct.org](mailto:planner@ledyardct.org)

*VIA EMAIL: [council@ledyardct.org](mailto:council@ledyardct.org)*

April 15, 2026

Chairman Gay St. Vil  
Ledyard Town Council  
741 Colonel Ledyard Highway

**RE:** Request Nominations - Ad Hoc Committee to Evaluate the Separation of the Planning & Zoning Commission

Dear Chairman St. Vil:

The Ledyard Planning & Zoning Commission, at its April 9, 2026, Regular Meeting, received the above-referenced request for the nomination of one qualified member of the Planning & Zoning Commission to join the Ad Hoc Committee to Evaluate the Separation of the Planning & Zoning Commission. With the endorsement of Chairman Marcelle Wood, Commissioner Beth Ribe satisfies all qualifications and has volunteered to serve on the Ad Hoc Committee for its 6 month duration.

Please contact me with any questions. Thank you for your attention to this matter.

Sincerely,

*Liz Burdick*

Director of Land Use & Planning for  
Ledyard Planning & Zoning Commission

C: Planning & Zoning Commission Chairman, Marcelle Wood  
Administrative Assistant to the Ledyard Town Council, Roxanne Maher  
Assistant to the Director, Anna Wynn  
Mayor Fred Allyn III  
Planning & Zoning Commissioner, Beth Ribe

**Application Form****Profile**

Milton

First Name

D

Middle  
Initial

Schroeder Jr

Last Name

mltnschroeder@yahoo.com

Email Address

290 Whalehead Rd

Home Address

Suite or Apt

Gales Ferry

City

CT

State

06335

Postal Code

Home: (860) 464-9327

Primary Phone

Alternate Phone

**Which Boards would you like to apply for?**

Ad Hoc Committee to Evaluate the Separation of the Planning Commission & Zoning Commission: Submitted

**Education & Experiences**

Please tell us about yourself and why you want to serve.

**Why are you interested in serving on a board or commission?**

I would like to use my experience and skill set to help the town, and I have the time to do so.

**Community Involvement**

Actively working on multiple initiatives with Citizen's Alliance for Land Use (CALU)

**Educational Background**

Ledyard Public Schools K-8, 12 High Wycombe High School (DODS), UK 9-11 Carnegie-Mellon, Bachelors of Architecture Ecole Polytechnique Federale de Lausanne (Federal Polytechnic Institute Lausanne), Switzerland - Mastery of Timber Construction Berner Fachhochschule (Bernese University of Applied Sciences), Switzerland - Timber Engineering Sciences, major in Structural Engineering

Retired

Employer

Structural Engineer,  
Architect, Designer

Job Title

Upload a Resume

**Party Affiliation**

**Party Affiliation \***

---

Unaffiliated

---

**Disclaimer & FOIA Information**

Your attendance and active participation is important for the Committee to conduct its business. Any member of a Committee/Commission/Board who is absent from three (3) consecutive regular meetings and any intervening duly called special meetings shall be considered to have resigned from the Committee and the vacancy shall be filled, except that the Committee may vote to waive attendance requirements in each case where illness or other extenuating circumstances make it impossible for a member to meet the attendance requirements. It shall be the responsibility of the Chairman of the Committee to notify the Town Council or Mayor's office when a member has not properly performed his/her duties.

**Please Agree with the Following Statement**

---

**If selected as a board member, I understand that information on this application is subject to the Freedom of Information Act (FOIA) and may be disclosed to anyone requesting this information.**

---

I Agree

**Signature (type full name below)**

---

Milton D Schroeder Jr

**Application Form****Profile**

Edwin

First Name

S

Middle  
Initial

Murray

Last Name

murrayed9@gmail.com

Email Address

26 Devonshire Dr

Home Address

Suite or Apt

Gales Ferry

City

CT

State

06335

Postal Code

Home: (518) 928-5811

Primary Phone

Home: (518) 928-5811

Alternate Phone

**Which Boards would you like to apply for?**

Ad Hoc Committee to Evaluate the Separation of the Planning Commission & Zoning Commission: Submitted

**Education & Experiences**

Please tell us about yourself and why you want to serve.

**Why are you interested in serving on a board or commission?**

I believe it is my responsibility to be an active and productive member of the community. I also believe it is the responsibility of our governing organizations is to take care of all residents first and foremost. Every action and decision must support this principle. From time to time it becomes necessary to review our governing organizations to insure they are fulfilling their responsibilities as effectively as possible.

**Community Involvement**

In the four years living in Ledyard, I have found a number of important issues to commit my energies too. The key to anything I decide to be a part of is will it improve and/or protect our community. Additionally, I will devote the time and energy required for any position i am selected to fill for our town.

**Educational Background**

I have had the responsibility for the development of approximately 100 restaurants from concept to opening. I created a sales building program that included physical plant changes that were key to success. President of star up restaurant concept. Held position of Corporate Ombudsman reporting to the CEO. Mediated cases regarding franchisee - corporate relationship and employee - management issues.

Employer

Job Title

---

## Party Affiliation

### Party Affiliation \*

---

Republican

---

## Disclaimer & FOIA Information

Your attendance and active participation is important for the Committee to conduct its business. Any member of a Committee/Commission/Board who is absent from three (3) consecutive regular meetings and any intervening duly called special meetings shall be considered to have resigned from the Committee and the vacancy shall be filled, except that the Committee may vote to waive attendance requirements in each case where illness or other extenuating circumstances make it impossible for a member to meet the attendance requirements. It shall be the responsibility of the Chairman of the Committee to notify the Town Council or Mayor's office when a member has not properly performed his/her duties.

### Please Agree with the Following Statement

---

**If selected as a board member, I understand that information on this application is subject to the Freedom of Information Act (FOIA) and may be disclosed to anyone requesting this information.**

---

I Agree

### Signature (type full name below)

---

Edwin S Murray

**Application Form****Profile**

Edwin

First Name

S

Middle  
Initial

Murray

Last Name

murrayed9@gmail.com

Email Address

26 Devonshire Dr

Home Address

Suite or Apt

Gales Ferry

City

CT

State

06335

Postal Code

Home: (518) 928-5811

Primary Phone

Home: (518) 928-5811

Alternate Phone

**Which Boards would you like to apply for?**

Ad Hoc Committee to Evaluate the Separation of the Planning Commission & Zoning Commission: Submitted

**Education & Experiences**

Please tell us about yourself and why you want to serve.

**Why are you interested in serving on a board or commission?**

I believe it is my responsibility to be an active and productive member of the community. I also believe it is the responsibility of our governing organizations is to take care of all residents first and foremost. Every action and decision must support this principle. From time to time it becomes necessary to review our governing organizations to insure they are fulfilling their responsibilities as effectively as possible.

**Community Involvement**

In the four years living in Ledyard, I have found a number of important issues to commit my energies too. The key to anything I decide to be a part of is will it improve and/or protect our community. Additionally, I will devote the time and energy required for any position i am selected to fill for our town.

**Educational Background**

I have had the responsibility for the development of approximately 100 restaurants from concept to opening. I created a sales building program that included physical plant changes that were key to success. President of star up restaurant concept. Held position of Corporate Ombudsman reporting to the CEO. Mediated cases regarding franchisee - corporate relationship and employee - management issues.

Employer

Job Title

Upload a Resume

---

## Party Affiliation

### Party Affiliation \*

Republican

---

## Disclaimer & FOIA Information

Your attendance and active participation is important for the Committee to conduct its business. Any member of a Committee/Commission/Board who is absent from three (3) consecutive regular meetings and any intervening duly called special meetings shall be considered to have resigned from the Committee and the vacancy shall be filled, except that the Committee may vote to waive attendance requirements in each case where illness or other extenuating circumstances make it impossible for a member to meet the attendance requirements. It shall be the responsibility of the Chairman of the Committee to notify the Town Council or Mayor's office when a member has not properly performed his/her duties.

### Please Agree with the Following Statement

**If selected as a board member, I understand that information on this application is subject to the Freedom of Information Act (FOIA) and may be disclosed to anyone requesting this information.**

I Agree

### Signature (type full name below)

Edwin S Murray

Yes, the Ledyard Republican Committee supports Edwin Murray for this ADHOC Committee. He will bring a wealth of knowledge and experience to this committee.

Joe Gush

Ledyard RTC Nominating Committee Chairman



---

**File #:** 26-0618

**Agenda Date:** 5/27/2026

**Agenda #:** 5.

---

## APPOINTMENT

### **Motion/Request:**

MOTION to appoint Mr. David Gruszkowski ( R) 26 Saw Mill Drive, Ledyard, to the Retirement Board to complete a three (3) year term ending January 20, 2029 filling a vacancy left by Ms. DeGaetano.

### **Background:**

Mr. Gruszkowski is retired, and has a Bachelors and Masters in Industrial Engineering. Additional studies towards a Doctorate in Strategic Leadership.(Please see attached Application & Resume')

Mr. Gruszkowski has been a Ledyard resident for 29 years; and raised my family here.; and now that he is retired he would like to serve the community of Ledyard. I am now retired and plan on staying in Ledyard.

Mr. Gruszkowski has been an active member of the community, participating in local church activities; and with Boy Scout Troop 12 and supported his son's Eagle Scout Project to remove excessive brush and debris from the Saw Mill Pond parking and picnic area.

### **Administrative Notes:**

The Retirement Board has one regular member vacancy and two alternate member vacancies.  
Please see attached Roster.

### **Nominating Committee Recommendation:**

The RTC has endorsed Mr. Gruszkowski appointment to the Retirement Board (please see attached)

### **Minority Representation - CGS 9-167a:**

In accordance with Chapter IV; Section 8 of the Town Charter "Except as otherwise provided for in this Charter, the Town Council may appoint members to fill vacancies in other offices, boards, and commissions established by this Charter and by ordinance as vacancies may occur, and appointing members to such offices, boards, and commissions as may be created in the future. Such appointments shall be made by the Town Council for such terms and upon such conditions as provided in the respective ordinance".

Chapter IV, Section 9: "In making appointments and removals, the Town Council shall act by the affirmative votes of at least a majority of all its members.

All members of boards, commissions, and committees contained in this Charter, or subsequently created under this Charter, except members of the Building Code Board of Appeals, the Fire Marshal, and the Deputy Fire Marshal(s), shall be electors of the Town at the time of their appointment and during their terms of office."

Connecticut General Statutes

Sec. 9-167a. Minority representation. (a) (1) Except as provided in subdivision (2) of this subsection, the maximum number of members of any board, commission, legislative body, committee or similar body of the state or any political subdivision thereof, whether elective or appointive, who may be members of the same political party, shall be as specified in the following table:

Total Membership	Maximum from One Party
3	2
4	3
5	4
6	4
7	5
8	5
9	6
More than 9 Two-thirds of total membership	

(2) The provisions of this section shall not apply (A) to any such board, commission, committee or body whose members are elected wholly or partially on the basis of a geographical division of the state or political subdivision, (B) to a legislative body of a municipality (i) having a town meeting as its legislative body or (ii) for which the charter or a special act, on January 1, 1987, provided otherwise or (C) to the city council of an unconsolidated city within a town and the town council of such town if the town has a town council and a representative town meeting, the town charter provides for some form of minority representation in the election of members of the representative town meeting, and the city has a city council and a body having the attributes of a town meeting or (D) to the board of directors and other officers of any district, as defined in section 7-324, having annual receipts from all sources not in excess of two hundred fifty Thousand dollars.

(b) Prior to any election for or appointment to any such body, the municipal clerk, in cases of elections, and the appointing authority, in cases of appointments, shall determine the maximum number of members of any political party who may be elected or appointed to such body at such election or appointment. Such maximum number shall be determined for each political party in the following manner: From the number of members of one political party who are members of such body at the time of the election or appointment, subtract the number of members of such political party whose terms expire prior to the commencement of the terms for which such election or appointment is being held or made and subtract the balance thus arrived at from the appropriate number specified in column II of subsection (a) of this section.

## Application Form

---

### Profile

David

First Name

J

Middle  
Initial

Gruszkowski

Last Name

gruszkowski@sbcglobal.net

Email Address

26 Saw Mill Dr

Home Address

Suite or Apt

Ledyard

City

CT

State

06339

Postal Code

Mobile: (860) 287-6198

Primary Phone

Alternate Phone

### Which Boards would you like to apply for?

Retirement Board: Submitted

### Education & Experiences

Please tell us about yourself and why you want to serve.

#### Why are you interested in serving on a board or commission?

I moved to Ledyard 29 years ago and raised my family here. I would like to serve my community of Ledyard. I am now retired and plan on staying in Ledyard.

#### Community Involvement

I have always supported and participated in local church activities. I was an adult member of Troop 12 during my son's teenage years and supported his Eagle Project to remove excessive brush and debris from the Saw Mill Pond parking and picnic area.

#### Educational Background

I have a Bachelors and Masters in Industrial Engineering. Additional studies towards a Doctorate in Strategic Leadership

Retired

Employer

Job Title

[DJG\\_Resume\\_1-07-26.docx](#)

Upload a Resume

### Party Affiliation

David J Gruszkowski

**Party Affiliation \*** Republican**Disclaimer & FOIA Information**

Your attendance and active participation is important for the Committee to conduct its business. Any member of a Committee/Commission/Board who is absent from three (3) consecutive regular meetings and any intervening duly called special meetings shall be considered to have resigned from the Committee and the vacancy shall be filled, except that the Committee may vote to waive attendance requirements in each case where illness or other extenuating circumstances make it impossible for a member to meet the attendance requirements. It shall be the responsibility of the Chairman of the Committee to notify the Town Council or Mayor's office when a member has not properly performed his/her duties.

**Please Agree with the Following Statement**

**If selected as a board member, I understand that information on this application is subject to the Freedom of Information Act (FOIA) and may be disclosed to anyone requesting this information.**

 I Agree**Signature (type full name below)**

David Gruszkowski

To: Ledyard Town Council

From Ledyard RTC Nominating Committee Chairman - Joe Gush

I personally know David Gruszkowski through work and casually social. David has demonstrated excellent judgement in his critical decisions and ethics at work. He lives to these three words, legal, Moral and Just. David is an excellent candidate for this position on the Retirement Board

Joe Gush  
Ledyard RTC Nominating Committee Chairman

David J Gruszkowski

**David J. Gruskowski**

26 Sawmill Drive

Ledyard, CT 06339

860-287-6198

[Gruskowski@sbcglobal.net](mailto:Gruskowski@sbcglobal.net)**Objective      Program Management**

- 
- Qualifications**
- 4 years as Program Manager for the NNS Onsite Office Groton\New London CT
  - 5 years Manager Engineering for the NNS Onsite Office Groton\New London CT
  - 44 years shipyard related engineering, construction, quality, planning and test experience
  - 19 years managing Virginia Class Submarine, (VCS) on-site C3I Weapons Integration Test Team engineers
  - 12 years managing CCSM construction activities Groton CT & Quonset Point RI
  - Technical Leader and Technology System Development and Integration Leader, ManTech Integrated Test Link System
  - 30 years producing and giving presentations using Microsoft Power Point, Project, Excel and Word
  - 30 years VCS Design Build experience
  - VCS on-site liaison for the matters of Quality, Test, Dockside Security, Module Transfers and Construction with Newport News Shipbuilding, Electric Boat Groton and Quonset Point RI
  - Bachelor of Science in Industrial Engineering, BSIE  
Summa Cum Laude, ABET certified
  - Master of Science in Industrial Engineering, MSIE
- 

**Work****Experience  
(2022-2026)****Newport News Shipbuilding** Groton\New London, CT\Quonset Point RI  
**Program Manager**

- Program Manager for the NNS Onsite Office
  - Manage 33 Newport News Shipbuilding associates, Planning, Engineering, Operations and Analyst in Groton CT, New London CT, Quonset Point RI
  - Manage submarine Module deliveries
  - Responsible for Direct Charging and Sub-contractor Tasking
  - Manage Demand Order Feed
  - Maintain Organization Structure for meeting Project Goals
- 

**(2017-2022)****Newport News Shipbuilding** Groton\New London, CT\Quonset Point RI  
**Engineering Manager**

- Manage and Lead 8 Engineers for CLB and VCS Design Build Sustain, Emergent Engineering resolutions, Quality Investigations, Submarine Module Completions, ER, CR, and Demand Order Feed expediting
- Manage and Develop Task Instruction financial estimates and execution
- Manage and Lead Companywide Work Completion assessment
- Represent NNS at joint NNS\EB CLB and VCS Program meetings
- Coordinate Design Product delivery matrices for NNS President
- Manage Department VCS progressing
- Labor Resource Management

- 
- (2009-2017) **Newport News Shipbuilding** Groton, CT  
**Quality, Process & Test Manager**
- Program Office & Engineering Group Leader
  - Lead quality improvement initiatives
  - Coordinate Quality Item Matrix investigations and resolutions between Newport News Shipbuilding, Electric Boat Groton and Quonset Point RI
  - Presenter 1<sup>st</sup> Annual Test Evaluation Advisory Conference, (TEAG)
  - Manage Test Procedure deliverables to support ship and module testing, Groton CT & Quonset Point RI
- 

- (1997-2009) **Northrop Grumman Newport News** Groton, CT  
**Project Engineer**
- Test Engineering liaison between Electric Boat, Government (PMS450), vendors, and Newport News
  - On-site Non-Propulsion Electronics Joint Test Group member
  - Project Manager for NNS Command Control Systems Modules in the CCSM Off-hull Assembly Test Site facility
  - Leader of Lean Event Process Improvement team
  - Simplified VCS work transfer between Newport News and Electric Boat planning departments
  - Mentor Coach test engineers, technicians and construction supervisors
  - Designed and negotiated 480,000 man-hour VCS electronics test support contract with the United States Navy, PMS450
  - Schedule technical support over multiple years and task locations
  - Re-engineered manual process of capturing interface cable certification data to computer-based system eliminating errors, reducing cycle time
  - Lead engineer for the Automated Cable Certification System, (ACCS) proposal, joint Newport News/Gulf-Coast Man-Tech project
  - Reduced VCS certification paperwork requirements
  - Developed procedure manual for VCS Fiber Optic Cable testing
  - Editor governing documents for VCS teaming of government and vendor test personnel
- 

- (1989-1997) **Newport News Shipbuilding** Newport News, VA  
**Test Engineering Coordinator**
- Directed dockside and sea trial test certification of submarine combat systems
  - Coordinated *Opportunity for Improvement* program for test engineering
  - Led installation and test of television and radio systems with studios on aircraft carriers
  - Performed Weapons Certification on fast-attack submarines
  - Designed and developed the visually enhanced non-nuclear Test Procedure cover sheet
  - Developed proposals for submarine test support
- 

- (1981-1989) **UNISYS** Virginia Beach, VA  
**Senior Field Engineer**
- Computer system technical representative for Supervisor of Shipbuilding Newport News
  - Audited, groomed, repaired, and certified combat systems at Naval Land Based

Test Facility prior to shipboard installation

- 
- (1975-1981) United States Navy**  
**Data Systems Technician First Class**
- Managed Data Systems maintenance at the Fleet Support Facility Dam Neck VA
  - Supervised Naval Tactical Data System and Command Information Center maintenance on the USS Forrestal CV-59

---

**Additional Work Experience 2009 - present**      **University of New Haven West Haven, CT**  
 Adjunct Professor, Project Management, Engineering Management, Quality, Lean. Engineering Economics, Probability, Statistics, Earned Value Management System

- 
- Education (1997-2009)**      **University of New Haven**
- **Bachelor of Science in Industrial Engineering, BSIE**  
 Summa Cum Laude, ABET certified
  - **Master of Science in Industrial Engineering, MSIE**  
**Course Work includes:**

Strategic Management	Decision Analysis
Engineering Management	Facility Planning
Statistical Process Control	Human Resources
Engineering Economics	Six Sigma Quality
Inventory Control	Lean

**Regent University**

- **Doctoral studies in Strategic Leadership, (DSL)** - The Human Focus of Leadership and Leadership Theory and Development

**Certified Microsoft Professional**

**Newport News** - Value Stream Mapping

**Electric Boat** - 6010 Manual for the Control of Testing and Ship Conditions qualified, 40 hours

**Defense Acquisition University** - Fundamentals of Systems Acquisition Management

- 
- Awards**
- Submitted the winning scholarship essay to the Institute of Industrial Engineers on reducing cycle time and WIP
  - Inducted into the Alpha Sigma Lambda Honor Society

- 
- Proficiencies**
- Excellent written and verbal communication skills
  - Expert in Microsoft Excel, Word, Power Point, Project

- Arena Simulation

---

**Personal**

- Wood and Metalworking, Landscaping, Gardening
- Acted as General Contractor for two of my homes and personally performed design, land clearing, concrete, electrical, plumbing, carpentry and landscaping
- Married 42 years, 5 children, 9 grandchildren

**RETIREMENT BOARD**

	<b>Name</b>	<b>Term Expiration</b>
R	Thorne, William 3 Adios Lane Ledyard, Connecticut 06339	1/20/2027
R	Codding, Roger 13 Helmlock Circle Gales Ferry, Connecticut 06339	1/20/2028
D	Wadecki, Sharon 44 Fanning Road Ledyard, Connecticut 06339	1/20/2029
R	Rodolico, John (Chairman) 40 Long Pond Road Ledyard, Connecticut 06339	1/20/2028
	Vacant (DeGaetano, Minna)	1/20/2029

Alternate Members

R	Vacant (Codding, Roger)	8/26/2029
D	Vacant (DeGaetano, Minna)	8/26/2029

Non-Voting Members

Finance Director – Matthew Bonin, Finance Director  
Town Employee - Ian Stammel , Treasurer  
Town Council Liaison -

Town Council Appointment	3 Year Term	5 Reg. Members 2 Alt. Members  3 Ex-Officio Members  Finance Director Town Councilor Town Employee
--------------------------	-------------	---



# TOWN OF LEDYARD

741 Colonel Ledyard  
Highway  
Ledyard, CT 06339-1511

---

**File #:** 26-0619

**Agenda Date:** 5/13/2026

**Agenda #:** 6.

---

## APPOINTMENT

### **Motion/Request:**

MOTION to appoint Mr. Gary Schneider (D) 101 Inchcliffe Drive, Gales Ferry to the “*Ad Hoc Committee to Develop a Process for Capital Improvement Budding Projects for the Town of Ledyard*” as the Representative from the Community at Large, for six-month term in accordance with Res#002-2026/Feb 11.

### **Background:**

Mr. Schneider has a Bachelor of Science in Civil Engineering Master of Science in Industrial Engineering; and is currently employed as the Public Works Director in the Town of Groton. (see application & resume’)

Mr. Schneider has been an active member of the community. He is currently serving as a member of the Permanent Municipal Building Committee and was its former Chairman.

Mr. Schneider believes that small government like Ledyard needed to find subject matter experts within the citizens to support special projects such as the *Development of a Process for Capital Improvement Budding Projects*”.

### **Administrative Notes:**

The “*Ad Hoc Committee to Develop a Process for Capital Improvement Building Projects for the Town of Ledyard*” was a short-term six-month assignment. This Committee called for 7 Members, with six members being appointed at the Town Council’s April 22, 2026 meeting.

The seventh position was calling for a member from the Community-at-Large with Construction Management Experience.

Since the Town Council’s April 22, 2026 meeting the following two Appointment Applications have been received

- Mr. Gary Schneider
- Mr. Chuck Warrington

### **Nominating Committee Recommendation:**

5/11/2025: The DTC endorsed Mr. Schneider’s Appointment

### **Minority Representation - CGS 9-167a:**

In accordance with Chapter IV; Section 8 of the Town Charter “Except as otherwise provided for in this Charter, the Town Council may appoint members to fill vacancies in other offices, boards, and commissions

established by this Charter and by ordinance as vacancies may occur, and appointing members to such offices, boards, and commissions as may be created in the future. Such appointments shall be made by the Town Council for such terms and upon such conditions as provided in the respective ordinance”.

Chapter IV, Section 9: “In making appointments and removals, the Town Council shall act by the affirmative votes of at least a majority of all its members.

All members of boards, commissions, and committees contained in this Charter, or subsequently created under this Charter, except members of the Building Code Board of Appeals, the Fire Marshal, and the Deputy Fire Marshal(s), shall be electors of the Town at the time of their appointment and during their terms of office.”

**Connecticut General Statutes**

Sec. 9-167a. Minority representation. (a) (1) Except as provided in subdivision (2) of this subsection, the maximum number of members of any board, commission, legislative body, committee or similar body of the state or any political subdivision thereof, whether elective or appointive, who may be members of the same political party, shall be as specified in the following table:

Total Membership	Maximum from One Party
3	2
4	3
5	4
6	4
7	5
8	5
9	6
More than 9 Two-thirds of total membership	

(2) The provisions of this section shall not apply (A) to any such board, commission, committee or body whose members are elected wholly or partially on the basis of a geographical division of the state or political subdivision, (B) to a legislative body of a municipality (i) having a town meeting as its legislative body or (ii) for which the charter or a special act, on January 1, 1987, provided otherwise or (C) to the city council of an unconsolidated city within a town and the town council of such town if the town has a town council and a representative town meeting, the town charter provides for some form of minority representation in the election of members of the representative town meeting, and the city has a city council and a body having the attributes of a town meeting or (D) to the board of directors and other officers of any district, as defined in section 7-324, having annual receipts from all sources not in excess of two hundred fifty Thousand dollars.

(b) Prior to any election for or appointment to any such body, the municipal clerk, in cases of elections, and the appointing authority, in cases of appointments, shall determine the maximum number of members of any political party who may be elected or appointed to such body at such election or appointment. Such maximum number shall be determined for each political party in the following manner: From the number of members of one political party who are members of such body at the time of the election or appointment, subtract the number of members of such political party whose terms expire prior to the commencement of the terms for which such election or appointment is being held or made and subtract the balance thus arrived at from the appropriate number specified in column II of subsection (a) of this section.



# Application Form

## Profile

Gary \_\_\_\_\_ J \_\_\_\_\_ Schneider \_\_\_\_\_  
 First Name Middle Initial Last Name

council@ledyardct.org \_\_\_\_\_  
 Email Address

101 Inchcliffe Drive \_\_\_\_\_ Suite or Apt \_\_\_\_\_  
 Home Address

Gales Ferry \_\_\_\_\_ CT \_\_\_\_\_ 06335 \_\_\_\_\_  
 City State Postal Code

Home: (860) 464-2200 \_\_\_\_\_  
 Primary Phone Alternate Phone

## Which Boards would you like to apply for?

Ad Hoc Committee to Develop A Process For Capital Improvement Building Projects :  
 Submitted

## Education & Experiences

Please tell us about yourself and why you want to serve.

### Why are you interested in serving on a board or commission?

Need to support our form of town government. Small government like ours need to find subject matter experts within the citizens to support special projects.

## Community Involvement

Member PMBC

## Educational Background

Bachelor of Science in Civil Engineering Master of Science in Industrial Engineering

Town or Waterford \_\_\_\_\_ Director of Public Works \_\_\_\_\_  
 Employer Job Title

[Schneider.pdf.docx](#) \_\_\_\_\_  
 Upload a Resume

## Party Affiliation

**Party Affiliation \***

---

Democrat

---

**Disclaimer & FOIA Information**

Your attendance and active participation is important for the Committee to conduct its business. Any member of a Committee/Commission/Board who is absent from three (3) consecutive regular meetings and any intervening duly called special meetings shall be considered to have resigned from the Committee and the vacancy shall be filled, except that the Committee may vote to waive attendance requirements in each case where illness or other extenuating circumstances make it impossible for a member to meet the attendance requirements. It shall be the responsibility of the Chairman of the Committee to notify the Town Council or Mayor's office when a member has not properly performed his/her duties.

**Please Agree with the Following Statement**

---

**If selected as a board member, I understand that information on this application is subject to the Freedom of Information Act (FOIA) and may be disclosed to anyone requesting this information.**

---

I Agree

**Signature (type full name below)**

---

Gary J Schneider

## Roxanne Maher

---

**From:** Craig Breverman <cbreverman@gmail.com>  
**Sent:** Friday, May 8, 2026 7:30 PM  
**To:** Roxanne Maher  
**Subject:** Gary Schinder

Hi Roxanne,

I just got the finally vote needed to approve Gary.

I'm sorry it took so long.

Craig

## Comprehensive Career Summary of Gary J. Schneider

### Contact Information

Gary J. Schneider

101 Inchcliffe Drive

Gales Ferry, CT 06335

### Skills Summary and Profile

- Public sector leadership and management skills developed over three decades.
- Senior management experience in strategic planning, human resources, collective bargaining agreement negotiation and administration, contract dispute resolution, and environmental compliance.
- Expertise in consultant selection and management using Qualification Based Selection, in-house design with registered professional civil engineers, and administration of public works with large teams.
- Proficient in customer service, conducting internal and external audits, and preparing reports and presentations.
- Experience in closing landfills with advanced systems and piloting projects with EPA collaboration for energy recovery.
- Oversight of wastewater collection systems, advanced treatment facilities, and capital construction programs.
- Completion of multiple major municipal projects, including facilities and infrastructure upgrades.
- Skilled in municipal bonding, human resources administration, contract negotiation, budget preparation, and grant writing.
- Extensive public works experience in roads, streets, stormwater, solid waste, facilities, engineering, fleet operations, wastewater treatment, and capital construction.
- Developed and advised officials on public works issues at local, state, and national levels.
- Directed project teams, ensuring commitment to customer service, project goals, and budgets.
- Excellent written and verbal communication skills; comfortable presenting at televised meetings.

- Organized and capable of leading and directing concurrent activities.

## **Employment History**

### **Town of Waterford**

#### **November 2019 to Present – Public Works Department**

##### **Director of Public Works**

Senior department head serving as a member of the management team. Works closely with town, state, and federal agencies in the areas of roads and streets, facility management, fleet operations, municipal engineering, solid waste, and capital construction. Implements policy as adopted by the Board of Selectmen, sets departmental goals and vision, prepares and implements the annual department budget. Maintains positive relationships with residents, staff, and elected officials. Confident in public speaking, including televised formats.

### **Town of Groton**

#### **December 1991 to November 2019 – Public Works Department**

##### **Director of Public Works**

Led the Town of Groton's public works team, collaborating with municipal, state, and federal agencies. Oversaw roads and streets, facility management, fleet operations, engineering, solid waste, wastewater treatment, and capital construction. Implemented policy as adopted by the Town Council, set departmental goals, prepared and executed the annual budget. Maintained strong relationships with stakeholders and presented confidently in public and televised settings.

#### **July 1989 to December 1991 – Public Works Department**

##### **Deputy Director of Public Works**

Managed operational functions including solid waste management, wastewater treatment, and construction. Responsible for contract administration and general business affairs. Served as acting Director in the Director's absence.

#### **December 1983 to July 1989 – Public Works Department**

##### **Assistant Director of Public Works**

Administered construction contracts and business affairs for the department, including solid waste, wastewater treatment, and construction. Assumed Director responsibilities as needed.

### **General Dynamics – Electric Boat Division**

## **December 1978 to December 1983**

Selected for the Career Development Program and assigned to the management team in the Pipe Department. Contributed to the final construction and delivery of the first Trident submarine to the U.S. Navy.

## **US Army**

### **December 1975 to December 1979 (Active Duty), December 1979 to December 1995 (Reserves)**

Engineer Officer with assignments as Combat Engineer Platoon Leader and Facilities Manager for the largest separate Brigade. Served as Construction Officer for the Enewetak Atoll atomic cleanup. In reserve, contributed to facilities planning and engineering for the US Army Engineer District, New England.

## **Certifications**

- National Incident Management Systems: ISO 100, ISO 200 ICS for Single Resources, ISO 300 Intermediate ICS for Expanding Incidents, ISO 400 Advanced ICS for Command and General Staff, ISO 700 National Incident Management System
- ICS/EOC-191 Interface Workshop
- IED Awareness/Bomb Threat Management Workshop
- APWA Public Works Leadership Fellow (November 2011)
- Connecticut Licensed Tree Warden (September 2016)

## **Professional Associations**

- American Public Works Association (APWA)
- Solid Waste Association of North America (SWANA)
- Connecticut Association of Street and Highway Officials (CASHO)

## **Boards, Commissions, and Committees**

- Member, Board of Directors and Executive Committee, Southeastern Connecticut Regional Resources Recovery Authority
- Member, Connecticut Council of Municipalities, Committee on Environmental Management Knowledge Team
- PMBC, Town of Ledyard

RESOLUTION  
ESTABLISHING AN AD HOC COMMITTEE  
TO DEVELOP A  
PROCESS FOR CAPITAL IMPROVEMENT BUILDING PROJECTS  
FOR THE TOWN OF LEDYARD

WHEREAS: the Ledyard Town Council recognizes the Permanent Municipal Building Committee's efforts to execute and supervise the design, construction, renovation, demolition and removal of Town and Board of Education assigned buildings that fall within the approved budget, as well as any significant installation, renovation or upgrade of service equipment and major systems as assigned by the Town Council.

WHEREAS: The Permanent Municipal Building Committee and the Board of Education have requested the Town Council establish an Ad Hoc Committee comprised of key stakeholders that play a role in the building project process.

NOW, THEREFORE, BE IT RESOLVED, that there is hereby established an *Ad Hoc Committee to Develop A Process For Capital Improvement Building Projects for the Town of Ledyard* to be composed of seven (7) members appointed by the Ledyard Town Council.

Those members shall, as much as possible, be representative as follows:

- One member from the Permanent Municipal Building Committee
- One member from the Board of Education
- Board of Education Director of Facilities
- Public Works Director/Town Engineer
- Finance Director
- One member from the Community-at-Large with Construction Management Experience
- One member from the Town Council

The Committee shall hold its Organizational Meeting no later than 30 days after its appointment and shall elect a Chairman, and Recording Secretary.

The Committee Members shall serve for a six (6) month term. Any vacancies on said committee shall be filled by the appointment of the Ledyard Town Council with priority given to maintaining as much as possible the structure above.

BE IT FURTHER RESOLVED, that said Ad Hoc Committee shall:

1. Review the process for Town and School Building Projects.
2. Review Building Blocks and workflow for Building Projects.
3. Review Building Projects - Municipal Check List -1990.
4. Review Ordinance #100-015(rev1) "*An Ordinance Establishing a Permanent Municipal Building Committee for the Town of Ledyard*"
5. Evaluate the effectiveness of the Permanent Municipal Building Committee and options for the Town and Board of Education to better facilitate Capital Improvement Building Projects.

BE IT FURTHER RESOLVED, that said Ad Hoc Committee is authorized to:

Develop an end-to- end Process and Timeline/Schedule for assigned Municipal and Board of Education Capital Improvement Projects to include but not be limited to the following:

For example:

- a. Preliminary Design and Cost Estimates for Project.

- b. Present Project to Town Council and request seed money for the town to hire Architects/Engineering Design Professionals.
- c. Prepare, Advertise, Evaluate, and Recommend Selection for Requests for Qualification/ Requests for Proposals (Architects/Engineering Design, Owners Representative, Construction Components, etc. to facilitate the project).
- d. Present proposed Project with cost estimates to the Town Council to request funding to support the Project (i.e. Bond/Borrowing Documentation and/or Grant Funding).
  - If Bond/Borrowing is required work with Finance Department to provide information needed for Bond Council to prepare Bond Authorization documents.
  - Work with Town Council and Departments to present the Project at a Special Town Meeting in preparation for Referendum, in accordance with Town Charter, Chapter VII: Section 9.
- e. Identify other funding sources such as Grant Funding.
  - Work with Town and/or Board of Education and Professional Consultants to complete required Applications and Forms and to submit Grant Applications according to Grant Schedules.
- f. With the approval of funding proceed to execute and supervise the design, construction, renovation, demolition and removal of Town and Board of Education buildings that fall within the approved budget, as well as any significant installation, renovation or upgrade of service equipment and major systems to include the following:
  - Work with Owners Representative, to provide oversight of construction and schedules to ensure work is progressing at a at school facilities was not being done while students were in the buildings.
  - Work with contractors and staff to review and approve payment of invoices in a timely manner.
  - Formally close out project with a letter to the Town Council and other stakeholders.
  - Provide a final report to the Town Council.
- g. Develop a process for Problem Resolution for issues that arise during the construction such as non-performance, improper installation/work, and to address warranty items.

BE IT FURTHER RESOLVED, that said Ad Hoc Committee shall provide a report of their recommendations to the Town Council upon completion of their assignment, no later than six months from its Organizational Meeting.

Adopted by the Ledyard Town Council on: February 11, 2026

---

Gary St. Vil, Chairman

**AD HOC COMMITTEE**  
**DEVELOP PROCESS FOR CAPITAL IMPROVEMENT BUILDING PROJECTS**

Name	Representative	Term Expiration
Bonin, Matthew 741 Colonel Ledyard Highway Ledyard, Connecticut 06339	Finance Director	6 – Months
Donaldson, Wayne 4 Blonders Boulevard Ledyard, Connecticut 06339	BOE Director of Facilities	6 – Months
Graber, Brandon 42 Church Hill Road Ledyard, Connecticut 06339	Board of Education	6 – Months
Gush, Joseph 57 Town Farm Road Ledyard, Connecticut 06339	Pemanet Municipal Building Cmt (PMBC)	6- Months
Lamb, Ty (Earl) 95 Lambtown Road Ledyard, Connecticut 06339	Town Council	6 – Months
Masalin, Steve 741 Colonel Ledyard Highway Ledyard, Connecticut 06339	Public Works Director	6 - Months
<b>Vacant</b>	Community-at-Large With Construction Management Experience	6 - Months

Town Council Appointment                      Term: 6 Months

**Structure:**

- One member from the Permanent Municipal Building Committee
- One member from the Board of Education
- Board of Education Director of Facilities
- Public Works Director/Town Engineer
- Finance Director
- One member from the Community-at-Large with Construction Management Experience
- One member from the Town Council



**File #:** 26-0623

**Agenda Date:** 5/27/2026

**Agenda #:** 7.

APPOINTMENT

**Motion/Request:**

MOTION to appoint Ms. Anne Roberts-Pierson (U) 4 Anderson Drive, Gales Ferry, as a Regular Member to the Historic District Commission, to complete a five (5) year term ending December 6, 2029; filling a vacancy left by Ms. Lamb.

**Background:**

Historic District Commission Chairman Karen Parkinson has requested Alternate Member Ms. Anne Roberts-Pierson be appointed as a Regular Member to fill a vacancy left by Ms. Kelley Lamb (please see resignation letter).

**Administrative Notes:**

Please see Historic District Commission Roster.

**Nominating Committee Recommendation:**

(type text here)

**Minority Representation - CGS 9-167a:**

In accordance with Chapter IV; Section 8 of the Town Charter “Except as otherwise provided for in this Charter, the Town Council may appoint members to fill vacancies in other offices, boards, and commissions established by this Charter and by ordinance as vacancies may occur, and appointing members to such offices, boards, and commissions as may be created in the future. Such appointments shall be made by the Town Council for such terms and upon such conditions as provided in the respective ordinance”.

Chapter IV, Section 9: “In making appointments and removals, the Town Council shall act by the affirmative votes of at least a majority of all its members.

All members of boards, commissions, and committees contained in this Charter, or subsequently created under this Charter, except members of the Building Code Board of Appeals, the Fire Marshal, and the Deputy Fire Marshal(s), shall be electors of the Town at the time of their appointment and during their terms of office.”

**Connecticut General Statutes**

Sec. 9-167a. Minority representation. (a) (1) Except as provided in subdivision (2) of this subsection, the maximum number of members of any board, commission, legislative body, committee or similar body of the state or any political subdivision thereof, whether elective or appointive, who may be members of the same political party, shall be as specified in the following table:

Total Membership	Maximum from One Party
3	2
4	3
5	4
6	4
7	5
8	5
9	6
More than 9 Two-thirds of total membership	

(2) The provisions of this section shall not apply (A) to any such board, commission, committee or body whose members are elected wholly or partially on the basis of a geographical division of the state or political subdivision, (B) to a legislative body of a municipality (i) having a town meeting as its legislative body or (ii) for which the charter or a special act, on January 1, 1987, provided otherwise or (C) to the city council of an unconsolidated city within a town and the town council of such town if the town has a town council and a representative town meeting, the town charter provides for some form of minority representation in the election of members of the representative town meeting, and the city has a city council and a body having the attributes of a town meeting or (D) to the board of directors and other officers of any district, as defined in section 7-324, having annual receipts from all sources not in excess of two hundred fifty Thousand dollars.

(b) Prior to any election for or appointment to any such body, the municipal clerk, in cases of elections, and the appointing authority, in cases of appointments, shall determine the maximum number of members of any political party who may be elected or appointed to such body at such election or appointment. Such maximum number shall be determined for each political party in the following manner: From the number of members of one political party who are members of such body at the time of the election or appointment, subtract the number of members of such political party whose terms expire prior to the commencement of the terms for which such election or appointment is being held or made and subtract the balance thus arrived at from the appropriate number specified in column II of subsection (a) of this section.

## Roxanne Maher

---

**From:** karen parkinson <karen@thepaddockinc.com>  
**Sent:** Tuesday, May 5, 2026 4:19 PM  
**To:** Roxanne Maher  
**Subject:** historic District Commission membership

The Ledyard Historic Commission respectfully requests that Anne Roberts-Pierson be moved to a regular Commission from alternate, filling the vacancy left by Kelly Lamb

Karen Parkinson, Chair, Ledyard Historical Commission

## Roxanne Maher

---

**From:** Kelly Lamb <justme125@aol.com>  
**Sent:** Thursday, April 16, 2026 8:09 AM  
**To:** Roxanne Maher  
**Subject:** Fwd: Kelly Lamb

Roxanne,

I didn't realize until Christina reached out to me that I should have included you when i sent my resignation to Karen and Doug at the Ledyard Historical District Commission. Is it ok to forward the email, or do you need an actual letter?

Kelly Lamb  
Sent from my iPhone

Begin forwarded message:

**From:** Kelly Lamb <justme125@aol.com>  
**Date:** March 16, 2026 at 3:50:13 PM EDT  
**To:** karen parkinson <karen@thepaddockinc.com>, Doug B Kelley <dbkelley12@gmail.com>  
**Subject: Kelly Lamb**

Tonight I want to give you a heads up , due to my work schedules i will be giving my notice to the LHDC. Im hoping to help out for the next two months or shorter if you can get me a replacement.

I loved the time Ive spent with the commission, thank you for having me.

We will have to get someone to do social media- although i think Missy still has the credentials for adding members.

Kelly Lamb  
Sent from my iPhone



# TOWN OF LEDYARD

741 Colonel Ledyard  
Highway  
Ledyard, CT 06339-1511

---

**File #:** 26-0643

**Agenda Date:** 5/27/2026

**Agenda #:** 8.

---

## APPOINTMENT

### **Motion/Request:**

MOTION to appoint Ms. Kim Millar (U) 6 Riverside Place, Gales Ferry, as an Alternate Member to the Historic District Commission, to complete a five (5) year term ending December 6, 2028; filling a vacancy left by Ms. Roberts-Pierson.

### **Background**

Ms. Millar is a retired Pediatrician, where she practiced in Princeton NJ for 30 years. She has a BA Wesleyan University, 1979 Magna cum laude with Honors in Bio-Psychology MD Baylor College of Medicine, 1984 Pediatric internship and residency at Children's Hospital of Philadelphia, 1984-1987 Pediatrician at Princeton Nassau Pediatrics, Princeton NJ 1987-2017.

Ms. Millar is a native of Ledyard, and after moving away with her family to Scotland, Connecticut; where they bought and rehabbed a Cape Cod house that was built in 1707. She later settled in Princeton NJ where she had her retired Pediatric Practice and raised 4 children.

Ms. Millar's has been a community advocate through her medical practice on issues such as: bike safety (Wear Your Helmet), teen issues, healthy babies, parenting, learning differences, etc. She also served on the board of CASA (Court Appointed Special Advocates) in Mercer County; and on the Vestry of Trinity Episcopal Church. In addition she was a Girl Scout leader.

Ms. Millar has a passion for history, and became an avid researcher of her family's (Chapman) genealogy. She has visited Ledyard and Gales Ferry to explore cemeteries, old familiar streets, libraries.

When she and her husband retired, to Ledyard she organized, researched and documented several thousand photographs and memorabilia at the Yale compound in Gales Ferry, the renovation of the buildings that lead to a revitalization of the compound and increased interest amongst the Yale rowers in the history of the Yale-Harvard regatta. (please see Application and Resume")

### **Administrative Notes:**

With Kelly Lamb's resignation the Historic District Commission has one regular member vacancy. (Please see attached Roster)

### **Nominating Committee Recommendation:**

Ms. Millar is Registered Unaffiliated.

**Minority Representation - CGS 9-167a:**

In accordance with Chapter IV; Section 8 of the Town Charter “Except as otherwise provided for in this Charter, the Town Council may appoint members to fill vacancies in other offices, boards, and commissions established by this Charter and by ordinance as vacancies may occur, and appointing members to such offices, boards, and commissions as may be created in the future. Such appointments shall be made by the Town Council for such terms and upon such conditions as provided in the respective ordinance”.

Chapter IV, Section 9: “In making appointments and removals, the Town Council shall act by the affirmative votes of at least a majority of all its members.

All members of boards, commissions, and committees contained in this Charter, or subsequently created under this Charter, except members of the Building Code Board of Appeals, the Fire Marshal, and the Deputy Fire Marshal(s), shall be electors of the Town at the time of their appointment and during their terms of office.”

**Connecticut General Statutes**

Sec. 9-167a. Minority representation. (a) (1) Except as provided in subdivision (2) of this subsection, the maximum number of members of any board, commission, legislative body, committee or similar body of the state or any political subdivision thereof, whether elective or appointive, who may be members of the same political party, shall be as specified in the following table:

Total Membership	Maximum from One Party
3	2
4	3
5	4
6	4
7	5
8	5
9	6
More than 9 Two-thirds of total membership	

(2) The provisions of this section shall not apply (A) to any such board, commission, committee or body whose members are elected wholly or partially on the basis of a geographical division of the state or political subdivision, (B) to a legislative body of a municipality (i) having a town meeting as its legislative body or (ii) for which the charter or a special act, on January 1, 1987, provided otherwise or (C) to the city council of an unconsolidated city within a town and the town council of such town if the town has a town council and a representative town meeting, the town charter provides for some form of minority representation in the election of members of the representative town meeting, and the city has a city council and a body having the attributes of a town meeting or (D) to the board of directors and other officers of any district, as defined in section 7-324, having annual receipts from all sources not in excess of two hundred fifty Thousand dollars.

(b) Prior to any election for or appointment to any such body, the municipal clerk, in cases of elections, and the appointing authority, in cases of appointments, shall determine the maximum number of members of any

political party who may be elected or appointed to such body at such election or appointment. Such maximum number shall be determined for each political party in the following manner: From the number of members of one political party who are members of such body at the time of the election or appointment, subtract the number of members of such political party whose terms expire prior to the commencement of the terms for which such election or appointment is being held or made and subtract the balance thus arrived at from the appropriate number specified in column II of subsection (a) of this section.

**Application Form****Profile**

Kim \_\_\_\_\_ H \_\_\_\_\_ Millar \_\_\_\_\_  
 First Name Middle Initial Last Name

kim6gf@gmail.com \_\_\_\_\_  
 Email Address

6 Riverside Place \_\_\_\_\_ Suite or Apt \_\_\_\_\_  
 Home Address

Gales Ferry \_\_\_\_\_ CT \_\_\_\_\_ 06335 \_\_\_\_\_  
 City State Postal Code

Mobile: (609) 462-7035 \_\_\_\_\_  
 Primary Phone Alternate Phone

**Which Boards would you like to apply for?**

Historic District Commission: Submitted

**Education & Experiences**

Please tell us about yourself and why you want to serve.

**Why are you interested in serving on a board or commission?**

I was born in this area and lived in Ledyard until I was twelve. My mother's family (Chapman) goes way back in the Groton/Ledyard area, and I have fond memories of growing up here: Ledyard Center School, our house on Gallup Hill Rd, moving to the brand new Gallup Hill School after the Highlands were built, the Ledyard Fair, the Ledyard Oak, Vality, etc. We often visited my grandmother on Long Cove Rd, and I thought it was normal that all her neighbors were related to her (and to me). I also grew up with parents who loved historic homes, and we moved away from Ledyard to Scotland, CT, where they bought and rehabbed a Cape Cod house built in 1707. I became an avid researcher of my family's genealogy when my children were past their pre-school days; I visited Ledyard and Gales Ferry to explore cemeteries, old familiar streets, libraries. When both my husband and I retired, we bought a home on Riverside Place next to the Yale Crew quarters, a place dear to my husband's heart. During Covid, I recovered, organized, researched and documented several thousand photographs and memorabilia at the Yale compound. At the same time, the buildings were renovated, leading to a revitalization of the compound and increased interest amongst the Yale rowers in the history of the Yale-Harvard regatta. I strongly feel that Ledyard's history, especially that of "ordinary" people, is worth knowing, preserving, and disseminating to ourselves and future generations. I have the interest, background, and focus to be an asset to the Historic District Commission.

## Community Involvement

---

I was a practicing pediatrician in Princeton NJ for 30 years, raising 4 children. My community involvement came through advocacy in my practice: bike safety (Wear Your Helmet), teen issues, healthy babies, parenting, learning differences, etc. I was able to advise parents about what resources were available in the Princeton Community, and to make sure that my patients could access those resources. I was a Girl Scout leader for 4-5 years. I served on the the board of CASA (Court Appointed Special Advocates) in Mercer County for six years and on the Vestry of Trinity Episcopal Church for 10 years. I am experienced in working with others on joint efforts.

## Educational Background

---

BA Wesleyan University, 1979 Magna cum laude with Honors in Bio-Psychology MD Baylor College of Medicine, 1984 Pediatric internship and residency at Children's Hospital of Philadelphia, 1984-1987 Pediatrician at Princeton Nassau Pediatrics, Princeton NJ 1987-2017

Retired

Employer

Job Title

Upload a Resume

---

## Party Affiliation

### Party Affiliation \*

Unaffiliated

---

## Disclaimer & FOIA Information

Your attendance and active participation is important for the Committee to conduct its business. Any member of a Committee/Commission/Board who is absent from three (3) consecutive regular meetings and any intervening duly called special meetings shall be considered to have resigned from the Committee and the vacancy shall be filled, except that the Committee may vote to waive attendance requirements in each case where illness or other extenuating circumstances make it impossible for a member to meet the attendance requirements. It shall be the responsibility of the Chairman of the Committee to notify the Town Council or Mayor's office when a member has not properly performed his/her duties.

### Please Agree with the Following Statement

**If selected as a board member, I understand that information on this application is subject to the Freedom of Information Act (FOIA) and may be disclosed to anyone requesting this information.**

I Agree

### Signature (type full name below)

Kim H Millar

## Roxanne Maher

---

**From:** Kelly Lamb <justme125@aol.com>  
**Sent:** Thursday, April 16, 2026 8:09 AM  
**To:** Roxanne Maher  
**Subject:** Fwd: Kelly Lamb

Roxanne,

I didn't realize until Christina reached out to me that I should have included you when i sent my resignation to Karen and Doug at the Ledyard Historical District Commission. Is it ok to forward the email, or do you need an actual letter?

Kelly Lamb  
Sent from my iPhone

Begin forwarded message:

**From:** Kelly Lamb <justme125@aol.com>  
**Date:** March 16, 2026 at 3:50:13 PM EDT  
**To:** karen parkinson <karen@thepaddockinc.com>, Doug B Kelley <dbkelley12@gmail.com>  
**Subject: Kelly Lamb**

Tonight I want to give you a heads up , due to my work schedules i will be giving my notice to the LHDC. Im hoping to help out for the next two months or shorter if you can get me a replacement.

I loved the time Ive spent with the commission, thank you for having me.

We will have to get someone to do social media- although i think Missy still has the credentials for adding members.

Kelly Lamb  
Sent from my iPhone



# TOWN OF LEDYARD

741 Colonel Ledyard  
Highway  
Ledyard, CT 06339-1511

---

**File #:** 26-0638

**Agenda Date:** 5/27/2026

**Agenda #:** 9.

---

## APPOINTMENT

### **Motion/Request:**

MOTION to reappoint Ms. Sarah Martic ( R) 59R Long Pond Road, South, Ledyard, to the Ledyard Farmers' Market Committee for a three (3) year term ending May 9, 2029.

### **Background:**

Ms. Martic's term is due to expire in May and she is interested in continuing to serve on the Farmers Market.

### **Administrative Notes:**

(type text here)

### **Nominating Committee Recommendation:**

Ms. Martic's reappointment has been endorsed by the Ledyard Farmers' Market Committee and her respective party.

### **Minority Representation - CGS 9-167a:**

In accordance with Chapter IV; Section 8 of the Town Charter "Except as otherwise provided for in this Charter, the Town Council may appoint members to fill vacancies in other offices, boards, and commissions established by this Charter and by ordinance as vacancies may occur, and appointing members to such offices, boards, and commissions as may be created in the future. Such appointments shall be made by the Town Council for such terms and upon such conditions as provided in the respective ordinance".

Chapter IV, Section 9: "In making appointments and removals, the Town Council shall act by the affirmative votes of at least a majority of all its members.

All members of boards, commissions, and committees contained in this Charter, or subsequently created under this Charter, except members of the Building Code Board of Appeals, the Fire Marshal, and the Deputy Fire Marshal(s), shall be electors of the Town at the time of their appointment and during their terms of office."

### **Connecticut General Statutes**

Sec. 9-167a. Minority representation. (a) (1) Except as provided in subdivision (2) of this subsection, the maximum number of members of any board, commission, legislative body, committee or similar body of the state or any political subdivision thereof, whether elective or appointive, who may be members of the same political party, shall be as specified in the following table:

Total Membership	Maximum from One Party
3	2
4	3
5	4
6	4
7	5
8	5
9	6
More than 9 Two-thirds of total membership	

(2) The provisions of this section shall not apply (A) to any such board, commission, committee or body whose members are elected wholly or partially on the basis of a geographical division of the state or political subdivision, (B) to a legislative body of a municipality (i) having a town meeting as its legislative body or (ii) for which the charter or a special act, on January 1, 1987, provided otherwise or (C) to the city council of an unconsolidated city within a town and the town council of such town if the town has a town council and a representative town meeting, the town charter provides for some form of minority representation in the election of members of the representative town meeting, and the city has a city council and a body having the attributes of a town meeting or (D) to the board of directors and other officers of any district, as defined in section 7-324, having annual receipts from all sources not in excess of two hundred fifty Thousand dollars.

(b) Prior to any election for or appointment to any such body, the municipal clerk, in cases of elections, and the appointing authority, in cases of appointments, shall determine the maximum number of members of any political party who may be elected or appointed to such body at such election or appointment. Such maximum number shall be determined for each political party in the following manner: From the number of members of one political party who are members of such body at the time of the election or appointment, subtract the number of members of such political party whose terms expire prior to the commencement of the terms for which such election or appointment is being held or made and subtract the balance thus arrived at from the appropriate number specified in column II of subsection (a) of this section.



# TOWN OF LEDYARD CONNECTICUT OWN COUNCIL

741 Colonel Ledyard Highway  
Ledyard, CT 06339-1551  
(860) 464-3203  
FAX (860) 464-1485  
E-Mail Address:  
[council@ledvardct.org](mailto:council@ledvardct.org)

Chairman Gary St. Vil

April 28, 2026

Mrs. Pamela Ball, Chairman  
Ledyard Farmers' Market Committee  
674 Shewville Road  
Ledyard, Connecticut 06339

Dear Mrs. Ball:

A Member of the Ledyard Farmers' Market Committee are due for re-appointment as listed below. The Administration Committee of the Town Council would like your recommendations.

Please complete the shaded areas of each Commission members block and kindly return to the Town Council Office. .

**Ledyard Farmers' Market Committee**

**3 Year Term**

Member's Name	Party Affiliation	Term Expiration	Committee Recommendation	Town Council Endorsement	Attendance
Ms. Sarah Martic 59R Long Pond Road, South Ledyard, CT 06339	R	5/09/2026	<u>Y</u> N	Y N	<input checked="" type="checkbox"/> X } Excellen <input type="checkbox"/> } Good <input type="checkbox"/> } Fair <input type="checkbox"/> } Poor

Committee Comments:

\_\_\_\_\_ Sarah has been a great help on the committee by coordinating the music program, helping on-site and contributing great ideas for the market. \_\_\_\_\_

\_\_\_\_\_ Your assistance is greatly appreciated. Thank you for your attention regarding this request.

Sincerely,

Roxanne M. Maher  
Administrative Assistant  
to the Ledyard Town Council



# TOWN OF LEDYARD

741 Colonel Ledyard  
Highway  
Ledyard, CT 06339-1511

---

**File #:** 26-0631

**Agenda Date:** 5/27/2026

**Agenda #:** 10.

---

## APPOINTMENT

### **Motion/Request:**

MOTION to appoint Mr. Jeremy Norris (D) 12 Old Fort Lane, Ledyard, as an Alternate Member to the Ledyard Farmers' Market Committee to complete a three (3) year term ending February 26, 2029 filling a left by Mr. Hary.

### **Background:**

Mr. Norris is employed at Pfizer as an Inventory Management Technician. He has his Associates from Three Rivers Bachelors in Business Management with a minor in Philosophy from UMUC. (Please see application).

Mr. Norris is a military veteran resident of the town for over a decade and has been an active member of the community. He has been serving on the WPCA for 6 years and would like to further his involvement with the town. He would like to help make Ledyard the best it can be and would like to volunteer to serve on the Farmers Market.

### **Administrative Notes:**

The Farmers Market Committee currently had two Alternate Member Vacancies. (please see roster)

### **Nominating Committee Recommendation:**

(type text here)

### **Minority Representation - CGS 9-167a:**

In accordance with Chapter IV; Section 8 of the Town Charter "Except as otherwise provided for in this Charter, the Town Council may appoint members to fill vacancies in other offices, boards, and commissions established by this Charter and by ordinance as vacancies may occur, and appointing members to such offices, boards, and commissions as may be created in the future. Such appointments shall be made by the Town Council for such terms and upon such conditions as provided in the respective ordinance".

Chapter IV, Section 9: "In making appointments and removals, the Town Council shall act by the affirmative votes of at least a majority of all its members.

All members of boards, commissions, and committees contained in this Charter, or subsequently created under this Charter, except members of the Building Code Board of Appeals, the Fire Marshal, and the Deputy Fire Marshal(s), shall be electors of the Town at the time of their appointment and during their terms of office."

### **Connecticut General Statutes**

Sec. 9-167a. Minority representation. (a) (1) Except as provided in subdivision (2) of this subsection, the maximum number of members of any board, commission, legislative body, committee or similar body of the state or any political subdivision thereof, whether elective or appointive, who may be members of the same political party, shall be as specified in the following table:

Total Membership	Maximum from One Party
3	2
4	3
5	4
6	4
7	5
8	5
9	6
More than 9 Two-thirds of total membership	

(2) The provisions of this section shall not apply (A) to any such board, commission, committee or body whose members are elected wholly or partially on the basis of a geographical division of the state or political subdivision, (B) to a legislative body of a municipality (i) having a town meeting as its legislative body or (ii) for which the charter or a special act, on January 1, 1987, provided otherwise or (C) to the city council of an unconsolidated city within a town and the town council of such town if the town has a town council and a representative town meeting, the town charter provides for some form of minority representation in the election of members of the representative town meeting, and the city has a city council and a body having the attributes of a town meeting or (D) to the board of directors and other officers of any district, as defined in section 7-324, having annual receipts from all sources not in excess of two hundred fifty Thousand dollars.

(b) Prior to any election for or appointment to any such body, the municipal clerk, in cases of elections, and the appointing authority, in cases of appointments, shall determine the maximum number of members of any political party who may be elected or appointed to such body at such election or appointment. Such maximum number shall be determined for each political party in the following manner: From the number of members of one political party who are members of such body at the time of the election or appointment, subtract the number of members of such political party whose terms expire prior to the commencement of the terms for which such election or appointment is being held or made and subtract the balance thus arrived at from the appropriate number specified in column II of subsection (a) of this section.

**Application Form****Profile**

Jeremy

First Name

R

Middle  
Initial

Norris

Last Name

jeremynorris@gmail.com

Email Address

12 Old Fort Lane

Home Address

Suite or Apt

Ledyard

City

CT

State

06339

Postal Code

Home: (860) 941-6514

Primary Phone

Alternate Phone

**Which Boards would you like to apply for?**

Ledyard Farmers Market Committee: Submitted

**Education & Experiences**

Please tell us about yourself and why you want to serve.

**Why are you interested in serving on a board or commission?**

i have served for 6 years and running on the WPCA and i'd like to further my involvement with the town I love by serving on another board that i feel i could add positively to! i want to help make this town the best it can be!

**Community Involvement**

currently serving on the WPCA. military veteran resident of the town for over a decade

**Educational Background**

Associates from Three Rivers Bachelors in Business Management with a minor in Philosophy from UMUC

Pfizer

Employer

Inventory Management  
Technician

Job Title

Upload a Resume

**Party Affiliation**

**Party Affiliation \***

---

Democrat

---

**Disclaimer & FOIA Information**

Your attendance and active participation is important for the Committee to conduct its business. Any member of a Committee/Commission/Board who is absent from three (3) consecutive regular meetings and any intervening duly called special meetings shall be considered to have resigned from the Committee and the vacancy shall be filled, except that the Committee may vote to waive attendance requirements in each case where illness or other extenuating circumstances make it impossible for a member to meet the attendance requirements. It shall be the responsibility of the Chairman of the Committee to notify the Town Council or Mayor's office when a member has not properly performed his/her duties.

**Please Agree with the Following Statement**

---

**If selected as a board member, I understand that information on this application is subject to the Freedom of Information Act (FOIA) and may be disclosed to anyone requesting this information.**

---

I Agree

**Signature (type full name below)**

---

Jeremy Norris

**Roxanne Maher**

---

**From:** Craig Breverman <cbreverman@gmail.com>  
**Sent:** Wednesday, May 6, 2026 8:14 PM  
**To:** Roxanne Maher  
**Subject:** Committee Approvals

Hi Roxanne,

Carol and Jeremy have both been approved for their committees!

Thank you for all your support!

Craig

## Roxanne Maher

---

**From:** Roxanne Maher  
**Sent:** Monday, May 4, 2026 10:51 AM  
**To:** Craig Breverman  
**Cc:** Wendy Hellekson; Roxanne Maher  
**Subject:** Appoint Applications - DTC Recommendation  
**Attachments:** APPOINT APPLICAITON-SCHNEIDER-AD HOC CMT-CAPITAL BULDING PROCESS-2026-05-03.pdf; AD HOC COMMITTEE-CAPITAL PROJECTS-2026-05-04.docx; APPOINT APPLICAITON-SCHNEIDER-HISTORIC DISTRICT COMMISISON-2026-05-03.pdf; HISTORIC DISTRICT COMMISSION-2026-05-04.docx; APPOINT APPLICATION-NORRIS-FAMRERS MARKET COMT-2026-05-02.pdf; FARMES MARKET-2026-05-04.docx; APPT-ENORS-PR\_SC-2026-04-28-DTC.pdf

Good Morning Craig:

Please find attached the following Appointment Applications for the DTC to provide a recommendation:

- Gary Schneider – Ad Hoc Committee – Develop Process for Capital Improvement Projects
- Jermey Norris – Famers Market Cmt

I have also attached the current Rosters for each of these Committees.

Also, I have attached the Reappointment Request for the Parks, Recreation, & Senior Citizens Commission, that I sent out on April 29, 2026.

If you can get these back to me ASAP I can include them on the Adminstration Committee's Agenda that I will be posting Thursday morning.

Please let me know if you have any questions.

Thank you,  
Roxanne

*Roxanne M. Maher*  
Administrative Assistant to  
The Ledyard Town Council  
(860) 464-3203  
[council@ledyardct.org](mailto:council@ledyardct.org)

Town Hall Hours:  
Monday – Thursday 7:45 a.m. – 4:45 p.m.  
Closed on Friday

LEDYARD FARMERS' MARKET COMMITTEE

	Name	Term Expiration
R	Martic, Sarah 59R Long Pond Road, South Ledyard, Connecticut 06339	5/9/2026
D	Foltz, Ethan 894 Colonel Ledyard Highway Ledyard, Connecticut 06339	5/9/2028
D	Ball, Pamela 674 Shewville Road Ledyard, Connecticut 06339	5/9/2027
D	Grenger, Ellin 15 Bittersweet Drive Gales Ferry, Connecticut 06335	5/9/2027
D	Troy, Allison 147 Gallup Hill Road Ledyard, Connecticut 06339	5/9/2027
	<u>Alternate Members</u>	
	Vacant (Hary, Lauriann)	5/9/2026
R	Thorne, William 3 Adios Lane Ledyard, Connecticut 06339	2/26/2026
	Vacant (Hary, Peter)	2/26/2026

Appointed by Town Council

3 Year Term

5 Regular Members

3 Alternate Members



# TOWN OF LEDYARD

741 Colonel Ledyard  
Highway  
Ledyard, CT 06339-1511

---

**File #:** 26-0695

**Agenda Date:** 5/27/2026

**Agenda #:** 11.

---

## FINANCIAL BUSINESS REQUEST (FBR)

**Motion/Request:**

MOTION to authorize the expenditure of up to \$7,000 from Account #21090305-58920 (Acquisition of Open Space) to support a Long Pond Invasive Species Study.

**Background:**

(type text here)

**Department Comment/Recommendation:**

(type text here)

**Finance Director Comment/Recommendation:**

As of May 14, 2026, account #21090305-58920 has a balance of \$492,765. Of this amount, \$178,000 has already been committed by prior Council action leaving an available unencumbered balance of \$314,765.

**Mayor Comment/Recommendation:**

(type text here)



# TOWN OF LEDYARD

741 Colonel Ledyard  
Highway  
Ledyard, CT 06339-1511

---

**File #:** 26-0717

**Agenda Date:** 5/27/2026

**Agenda #:** 12.

---

## CONTRACT-LEASE

**Motion/Request:**

MOTION to authorize the Mayor to enter into a Listing Agreement with a Realtor to list 89 Town Farm Road for sale.

**Background- Terms:**

(type text here)

**Department Comment/Recommendation:**

(type text here)

**Finance Director Comment/Recommendation:**

(type text here)

**Mayor Comment/Recommendation:**

(type text here)



---

**File #:** 26-0734

**Agenda Date:** 5/27/2026

**Agenda #:** 13.

---

## FINANCIAL BUSINESS REQUEST (FBR)

### **Motion/Request:**

MOTION to MOTION to establish a new Board of Education Non-Lapsing Fund in accordance with CGS 171-10-248.

### **Background:**

#### **1/7/2026 Finance Committee Meeting:**

Discussion: Councilor Ryan provided some background explaining that last year the State Legislature adopted a new Public Act #24-45 “*An Act Concerning Education Mandate Relief*”; which basically obviates the “*Resolution Creating a Funding Mechanism for Making Annual Appropriations to a Capital Reserve Fund for the Board of Education*”. He noted that since 1988 the Resolution allowed for the Board of Education’s surplus at the end of the fiscal year to be transferred to their Capital Account to specially be used for Capital Expenses. He stated Public Act #24-45 allowed Connecticut Board of Educations to use *Non-Lapsing Accounts* to carry over unspent education funds (up to 2% of the prior budget) for future *Educational Expenses*.

Councilor Ryan went on to explain that it was his understanding that the Board of Education currently does not have “*Non-Lapsing Account*”, noting that a new fund would need to be set-up. School Superintendent Jason Hartling stated that the Board of Education would transfer their budget surplus to their Capital Non-Recurring Fund. However, he noted that per Public Act #24-45 that the funds did not have to solely be used for Capital Expenses, noting that the Public Act stated the surplus funds were to be used for “*Future Educational Expenses*”.

Councilor Ryan stated Public Act #24-45 would take precedent over the 1988 “*Resolution Creating a Funding Mechanism for Making Annual Appropriations to a Capital Reserve Fund for the Board of Education*” to the extent that it allows the surplus funds to be transferred, noting that the language of Public Act #24-45 stated: “*Notwithstanding any existing ordinance; or any existing requirement in a Municipal Charter*”. However, he stated in accordance with Chapter VII of the Ledyard Town Charter that the Town Council was responsible “*for appropriating all non-budgeted revenue*”. Therefore, he stated regardless of what Public Act #24-45 said that the Town Council would still be required to act to transfer the funds, noting that the Board of Education could not transfer the funds. He stated if their Town Charter was silent or did not address that financial power, and give it to the Town Council; that the Board of Education could at its own discretion transfer their year-end budget surplus.

Finance Director Matthew Bonin explained the following terms:

#### **Non-Lapsing Fund:**

- Was a Special Fund where unspent education funds don't automatically revert to the town's general fund at year-end.
- Would allow the Board of Education to save and use surplus funds for educational needs in subsequent years, rather than losing them.
- It was not solely for the Capital Expenses.

**Capital Non-Recurring Fund:**

- Used specifically for Capital Expenses
- It could not be used for other educational purposes.

Mr. Bonin went on to explain for the Board of Education to transfer up to 2% of their year-end budget surplus for *Future Educational Expenses* that a new *Non-Lapsing Fund* would need to be set-up.

Councilor Garica-Irizarry questioned the process going forward if they cancelled the 1988 “*Resolution Creating a Funding Mechanism for Making Annual Appropriations to a Capital Reserve Fund for the Board of Education*”.

Councilor Ryan stated because there would be reporting requirements for Auditing purposes that it would behoove them to have some controls in-place on how the funds were expended, noting that the funds would be transferred on the Board of Education’s side of the ledger.

Councilor Buhle questioned how Mayor Allyn, III and Superintendent Hartling interpreted Public Act #24-45 in relation to the Town Charter.

Superintendent Hartling stated that it was complex noting the following:

- State Law when it was in conflict with the Town Charter, supersedes. He stated the Town Charter could not override State Law.
- Town Council’s February 28, 2024’s action set-up a new, stand alone, *Board of Education Capital Fund for Non-Bonded Board of Education Capital Items* to reside outside of the Town’s Capital Non-Recurring Fund (CNR Fund 210) (Non-Lapsing Account). Mr. Hartling stated this account already exists on the Board of Education’s side of the budget ledger and was under the authority of the Board of Education per Public Act #24-45.
- Under State Law, each year the Town Councils gives the Board of Education an annual appropriation (Annual Budget). For Fiscal Year 2025/2026 the Board of Education’s annual appropriation was \$40,667,242. He stated that \$40,667,242 was exclusively under the direction of the Board of Education. He explained that Public Act #24-25 stated that if the Board of Education had funds remaining at the end of the fiscal year that they could transfer those fund (up-to 2%) into the Board of Education’s *Non-Lapsing Account*; without anyone telling them how to use those funds. He stated that the Board of Education has indicated that they would use those funds in the *non-Lapsing Account for Capital Needs*.

· 1988 “*Resolution Creating a Funding Mechanism for Making Annual Appropriations to a Capital Reserve Fund for the Board of Education*” - Mr. Hartling explained that the Resolution stated that the Board of Education’s year-end budget surplus would be appropriated to their Capital Non-Recurring Account to be used solely for Capital Expenses. He stated the Board of Education’s current position was that the 1988 Resolution was not in-conflict with Public Act #24-25 and did not present any problem or risk to the town. He stated by keeping the 1988 Resolution in-place would require them to wait until the Annual Audit was completed before the surplus funds could be transferred to the Capital Non-Recurring Account.

Mayor Allyn, III noted Mr. Hartling’s statement that “*the Board of Education has indicated that they would use those funds in the non-Lapsing Account for Capital Needs.*” Therefore, he suggested, as was done in 1988 that this intention be put in writing via a Resolution or Policy that the Board of Education’s year-end budget surplus would be appropriated to their Capital Non-Recurring Account.

Mr. Hartling stated because the Board of Education’s year-end budget surplus would be a one-time infusion of funding that it should not be used for on-going operational costs and should be solely used for one-time Capital Expenses. However, he stated it would be the Board of Education’s decision on how to use their year-end budget surplus which in according to Public Act #24-45 could be used for educational purposes; and whether they wanted to implement a Policy, noting that it would be at the Board of Education’s discretion.

Councilor Ryan stated that he generally agreed that State Law would supersede Local Law unless there was a carve out. He stated Public Act #24-45 included a carve-out noting that it stated: “*For the Fiscal Year Ending June 30, 2024; and each fiscal year thereafter, notwithstanding any provisions of the General Statutes, or any Special Act, Municipal Charter, Home Rule Ordinance, or other Ordinance, a local Board of Education may deposit into a Non-Lapsing Account....*” Therefore, he stated the Town Charter would take precedence, which provides the Town Council the power to appropriate any non-budgeted revenues, which again, this would be. Mr. Hartling stated the second the funds were allocated the to the Board of Education during the Annual Budget Process, that those funds were a budgeted revenue. He stated that once the Board of Education has its budget that the Town Council does not get to pick what the Board of Education spend those funds on.

Councilor Ryan asked Finance Director Matthew Bonin whether the year-end budget surplus a non-budgeted revenue. Mr. Bonin explained that the movement of the Board of Education’s Fiscal Year 2024/2025 year-end budget surplus would take place in the Fiscal Year 2025/2026; because the prior fiscal year budget (fy 24/25) was closed. Therefore, he stated currently there was no budget to transfer those funds to. Mr. Hartling stated that Mr. Bonin was correct, in that the Board of Education does not have a mechanism, to move their year-end surplus, because the funds reside in the General Fund, noting that the Board of Education does not have access to the General Fund, noting that this was a process piece; and not a conflict with the State Law.

Councilor Ryan stated that there appeared to be some interpretation her. However, he stated that he thought what Mr. Hartling was saying was that the 1988 “*Resolution Creating a Funding Mechanism for Making Annual Appropriations to a Capital Reserve Fund for the Board of Education*” did not need to be cancelled. Mr. Hartling stated Councilor Ryan’s understanding was 100% correct.

Councilor Buhle stated that based on their discussion, there does not seem to be any harm if they keep the 1988 “*Resolution Creating a Funding Mechanism for Making Annual Appropriations to a Capital Reserve Fund for the Board of Education*”.

Councilor Ryan stated because Public Act #24-45 does not require the Board of Education to transfer their year-end surplus to a Capital Account, that he would agree with Mayor Allyn's suggestion that the Board of Education put in writing their intention with the adoption of a formal Resolution, that they would transfer/appropriate their year-end budget surplus to their Capital Non-Recurring Account.

**VOTE: 0- 3 Motion Failed**

**Department Comment/Recommendation:**

(type text here)

**Finance Director Comment/Recommendation:**

(type text here)

**Mayor Comment/Recommendation:**

(type text here)

**Substitute House Bill No. 5437**

source-separated organic material composting facility that has available capacity and that will accept such source-separated organic material. For the purposes of this section "institution" means any establishment engaged in providing hospitality, entertainment or rehabilitation and health care services, and any hospital, public or [private educational] independent institution of higher education building or facility or correctional facility.

(5) On and after July 1, 2026, each public or nonpublic school building or educational facility in which students in grades kindergarten to twelve, inclusive, or any combination thereof, are enrolled, that is located not more than twenty miles from either an authorized source-separated organic material composting facility and that generates an average projected volume of not less than twenty-six tons per year of source-separated organic materials shall: (A) Separate such source-separated organic materials from other solid waste; and (B) ensure that such source-separated organic materials are recycled at any authorized source-separated organic material composting facility that has available capacity and that will accept such source-separated organic material.

Sec. 7. Section 10-248a of the general statutes is repealed and the following is substituted in lieu thereof (*Effective from passage*):

For the fiscal year ending June 30, [2020] 2024, and each fiscal year thereafter, notwithstanding any provision of the general statutes or any special act, municipal charter, home rule ordinance or other ordinance, [the board of finance in each town having a board of finance, the board of selectmen in each town having no board of finance or the authority making appropriations for the school district for each town] a local board of education may deposit into a nonlapsing account any unexpended funds from the prior fiscal year from the budgeted appropriation for education, [for the town,] provided (1) such deposited amount does not exceed two per cent of the total budgeted appropriation for education for such prior fiscal year, (2) each

**Substitute House Bill No. 5437**

expenditure from such account shall be made only for educational purposes, and (3) each such expenditure shall be authorized by the local board of education for such town.

Sec. 8. Subdivision (2) of subsection (d) of section 10-51 of the general statutes is repealed and the following is substituted in lieu thereof (*Effective from passage*):

(2) [On and after June 7, 2006] For the fiscal year ending June 30, 2024, and each fiscal year thereafter, a regional board of education, by a majority vote of its members, may create a reserve fund for [capital and nonrecurring] educational expenditures. Such fund shall thereafter be termed ["reserve fund for capital and nonrecurring expenditures"] "reserve fund for educational expenditures". The aggregate amount of annual and supplemental appropriations by a district to such fund shall not exceed two per cent of the annual district budget for such fiscal year. Annual appropriations to such fund shall be included in the share of net expenses to be paid by each member town. Supplemental appropriations to such fund may be made from estimated fiscal year end surplus in operating funds. Interest and investment earnings received with respect to amounts held in the fund shall be credited to such fund. The board shall annually submit a complete and detailed report of the condition of such fund to the member towns. Upon the recommendation and approval by the regional board of education, any part or the whole of such fund may be used for [capital and nonrecurring] educational expenditures, [, but such use shall be restricted to the funding of all or part of the planning, construction, reconstruction or acquisition of any specific capital improvement or the acquisition of any specific item of equipment.] Upon the approval of any such expenditure an appropriation shall be set up, plainly designated for the [project or acquisition] educational expenditure for which it has been authorized. [, and such unexpended appropriation may be continued until such project or acquisition is completed.] Any

## CGS CHAPTER 171\* TOWN MANAGEMENT

**Sec. 10-248a. Unexpended education funds account.** For the fiscal year ending June 30, 2024, and each fiscal year thereafter, notwithstanding any provision of the general statutes or any special act, municipal charter, home rule ordinance or other ordinance, a local board of education may deposit into a nonlapsing account any unexpended funds from the prior fiscal year from the budgeted appropriation for education, provided

(1) such deposited amount does not exceed two per cent of the total budgeted appropriation for education for such prior fiscal year,

(2) each expenditure from such account shall be made **only for educational purposes**,  
and

(3) each such expenditure shall be authorized by the local board of education for such town.

(P.A. 10-108, S. 32; P.A. 19-117, S. 285; P.A. 21-40, S. 9; **P.A. 24-45**, S. 7.)

History: P.A. 10-108 effective July 1, 2010; P.A. 19-117 replaced “2011” with “2020”, designated existing provision re amount of total budgeted appropriation for education as Subdiv. (1) and amended same to add “deposited” and replace “one per cent” with “two per cent”, and added Subdiv. (2) re expenditures from account to be made only for educational purposes and added Subdiv. (3) re expenditure to be authorized by local board of education, effective July 1, 2019; P.A. 21-40 made a technical change; **P.A. 24-45 replaced “June 30, 2020” with “June 30, 2024”, replaced “the board of finance in each town having a board of finance, the board of selectmen in each town having no board of finance or the authority making appropriations for the school district for each town” with “a local board of education” and deleted “for the town,”**, effective May 21, 2024.

## Roxanne Maher

---

**From:** Gary St. Vil  
**Sent:** Tuesday, May 5, 2026 5:19 PM  
**To:** Jessica Buhle  
**Cc:** Roxanne Maher; jreguin@ledyard.net; Jason S. Hartling; Fred Allyn, III; Matthew Bonin; Town Council Group  
**Subject:** BOE Surplus Transfer & Reimbursement – Finance Committee Review  
**Attachments:** Board of Education Fiscal Year 2024-2025 Budget Surplus Transfer-ltr-2026-03-30.pdf; Finance Director response to BOE communication dated March 30 2026.pdf

Councilor Buhle,

Please have the Finance Committee review the attached correspondence from the Board of Education and the Finance Director regarding the FY24–25 surplus transfer and the Eversource reimbursement.

There appears to be a difference in how these funds are being treated from a process and statutory standpoint. I'd like the Committee to review and provide a recommendation on the appropriate path forward to ensure we are aligned and handling the funds correctly. This should include clarification on the proper handling of the surplus funds and reimbursement, and any required Council actions. The goal is to support the Board of Education's intent while ensuring we are following the proper municipal process.

Please let me know if you need any additional support.

Respectfully,

**Gary A. St. Vil**

Chairman, Ledyard Town Council  
741 Colonel Ledyard Highway  
Ledyard, CT 06339  
(860) 980-0656 | gsvil@ledyardct.org  
www.ledyardct.org



# Ledyard Public Schools

Administrative Offices

March 30, 2026

Ledyard Town Council  
% Mrs. Jessica Buell, Chair - Finance Committee  
Town of Ledyard  
741 Colonel Ledyard Highway  
Ledyard, CT 06339

Dear Chairman Buell,

The Board of Education at its September 9, 2025 authorized the transfer of the 2024-2025 fiscal year reserve amount to the Capital Non-Recurring account (CNR). The amount per the final audit results is \$212,301.

In addition, the Board of Education Finance Committee at its March 10, 2026 meeting, took formal action to direct the deposit of the check received from Eversource Energy for reimbursement of steam trap surveys for \$19,943 dated 12/02/2025 to the Board's CNR account. This reimbursement was budgeted as part of the anticipated cost. A copy of the check that was delivered to the town offices on January 8, 2026 is enclosed.

Please let me know if you have any questions. Thank you for your attention to this matter.

Sincerely,  
  
Jenn Reguin

Cc: Jason S. Hartling, Superintendent of Schools

CL+P - DISTRIBUTION DBA EVERSOURCE ENERGY

Bank of America Higher Standards

969526

106

51-44  
119 CT

DATE:  
12/03/2025

PAY Nineteen Thousand Nine Hundred Forty-Three Dollars & 00/100 US Dollars

USD: \$19,943.00

TO THE LEDYARD PUBLIC SCHOOLS  
ORDER OF 24 GALLUP HILL RD  
LEDYARD CT 06339 UNITED STATES

*John M. Moran*  
Authorized Signature

⑈0000969526⑈ ⑆011900445⑆ 00000070684⑈

CL+P - DISTRIBUTION DBA EVERSOURCE ENERGY  
PO BOX 5017, HARTFORD, CT 06102-5017

969526  
Date:12/02/2025

LEDYPUSC-000

VOICE DATE	INVOICE No	PO#	DISC AMT	CURR	PAYMENT AMT
7/28/2025	PB-128628		\$	USD	\$19,943.00
Pymt Comments: ATTN WAYNE DONALDSON. LEDYARD GALLUP HILL HS STEAM SURVEY CT25S02852777.					

Total: \$19,943.00

000154





Town of Ledyard  
Connecticut  
**FINANCE DEPARTMENT**  
741 Colonel Ledyard Highway  
Ledyard, CT 06339  
Tel: 860-464.3235

Finance Director  
Matthew Bonin

Assistant Finance Director  
Ian Stammel

April 22, 2026

Ledyard Town Council  
c/o Chairman Gary St. Vil  
741 Colonel Ledyard Hwy  
Ledyard, CT 06339

Chairman St. Vil,

I would like to share my comments in response to the letter from the Board of Education Chairman that was addressed to the Ledyard Town Council on March 30<sup>th</sup> 2026 and attached to the April 8<sup>th</sup> 2026 Town Council agenda.

Regarding the first item referencing the Board of Education FY 2024-2025 audit surplus of \$212,031 and the related transfer of the funds to the Board of Education Capital Non-Recurring (CNR) account, as I have stated on more than one occasion publicly, these funds cannot go directly in the Board of Education's CNR account as based on the legislation, these funds are not strictly capital in nature. Additionally, I had asked the auditor about this during the audit presentation at the finance committee meeting on February 4<sup>th</sup>, 2026. He agreed with my assertion. I would also like to point out that both the Superintendent and Board of Education chair were present at that meeting. The correct course of action is for the Council to authorize the appropriation and transfer of these funds to a new non-lapsing Board of Education fund that would be set up solely for the intended purposes of this legislation. If the Board of Education wishes to utilize these funds for capital purposes, they are certainly entitled to do that, but it would take Board action to move the funds from the new non-lapsing fund into the Board of Education CNR account as that is spelled out in the legislation.

Regarding the \$19,943 reimbursement from Eversource, the original expenditures took place in fiscal year 2024-2025. When the Board of Education finance office sent the check over to the Town finance department, there was a request to net it against the expenditure account that these funds were originally expensed out of in fiscal year 2024-2025. As that year was already closed out, that was not feasible. The check was deposited into the general fund

miscellaneous revenue account. I instructed the Board of Ed finance director that the best course of action would be to initiate a formal request to Town Council to transfer these funds into the Board of Education's CNR account. I have no issue with moving the funds, but it is going to require Town Council action to do so.

It should also be noted that per the Town Charter, as both of these items are non-budgeted appropriations, they will require Town Council action in order to be moved.

Sincerely,

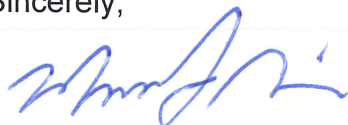

Matthew Bonin  
Director of Finance

Cc Fred B. Allyn III, Mayor



---

**File #:** 25-3018

**Agenda Date:** 1/7/2026

**Agenda #:**

---

## RESOLUTION

### **Motion/Request:**

MOTION to cancel “*Resolution Creating a Funding Mechanism for Making Annual Appropriations to a Capital Reserve Fund for the Board of Education*” adopted on September 28, 1988.

### **Background:**

Based on new State Legislation (Public Act 24-25) the Board of Education has the authority to transfer unexpended funds from the education budget into a non-lapsing account. Therefore, the 1988 “*Resolution Creating a Funding Mechanism for Making Annual Appropriations to a Capital Reserve Fund for the Board of Education*” was no longer required; and was being cancelled.

**Finance Committee Meeting 10/15/2025:** School Superintendent Jason Hartling explained with the implementation of a New State Statute that the Board of Education already took action to transfer their Fiscal Year 2024/2025 Year-End Balance to their Capital Non-Recurring (CNR) Account.

Finance Director noted that the Year-End Balance would not be available until the Annual Audit for Fiscal Year 2024/2025 has been completed; and therefore, the funds could not be transferred until the Annual Audit has been completed.

**Connecticut State Statute Section 10- 248a** to provide funding resources solely for future Board of Education.

Previous state law (*Connecticut General Statutes §10-248a*) permitted a town board of finance (or the board of selectmen in a town with no board of finance, or the authority otherwise making budget appropriations for the school district) to deposit unexpended funds from the education budget into a non-lapsing account

However, **Public Act 24-25** now allowed for Connecticut Board of Educations to use non-lapsing accounts to carry over unspent education funds (up to 2% of the prior budget) for future educational expenses, a practice clarified and expanded by recent legislation (like Public Act 24-45). These accounts require annual reporting to the Connecticut State Department of Education (SDE) and certified employee unions, detailing balances, deposits, and expenditures, effective for FY 2026 and beyond, ensuring transparency for these funds used only for educational purposes.

### **What is a Non-Lapsing Account?**

- It's a special fund where unspent education funds don't automatically revert to the town's general fund at year-end.
- Allows BOEs to save and use surplus funds for educational needs in subsequent years, rather than losing them.

**Key Legal Changes & Requirements:**

- **Authority:** Local BOEs can now deposit funds directly, rather than relying solely on the town's fiscal authority.
- **Limits:** Deposits can't exceed 2% of the previous year's education budget.
- **Purpose:** All spending from the account must be for educational purposes and authorized by the BOE.
- **Reporting (Starting FY 2026):** BOEs must report annually to the SDE and employee unions on:
  - Total account balance.
  - Amount deposited during the fiscal year.
  - Detailed accounting of expenditures.
  - Intended uses for the funds in the next fiscal year (with notification to the SDE and unions).

**Who Manages It?**

- The local Board of Education authorizes deposits and expenditures, although the Town's Board of Finance or similar body may need to approve the deposit itself, depending on the town's structure.

**Regional Boards of Education: Authority to Use Reserve Funds for Any Educational Purpose**

Currently, state law (Connecticut General Statutes §10-51(d)(2) allows regional boards of education to create reserve funds for “capital and non-recurring expenditures,” to be financed by appropriated funds and year end surplus operating (budget) funds.

Beginning with the 2023-2024 fiscal year (i.e., now), Section 8 of Public Act 24-45 will allow regional boards of education to create (and expend monies from) these funds for any “educational expenditure,” not just capital projects/improvements and equipment purchases. The Act renames the account “*the reserve fund for educational expenditures*” instead of the former “*reserve fund for capital and nonrecurring expenditures.*”

The other current restrictions for these reserve funds will remain in effect (for example, that such accounts be created by a majority vote of the regional board of education’s members, the aggregate amount of annual appropriations and supplemental appropriations from the surplus by the regional district to the fund cannot exceed 2% of the annual district budget for the fiscal year). However, this new provision provides an additional tool for regional school districts to consider when determining what to do with any surplus, and whether to 1) reduce the budget assessments to their member towns for the next year, or 2) use the surplus for educational purposes in the future via a deposit into a reserve fund.

**Department Comment/Recommendation:**

(type text here)

**Mayor Comment/Recommendation:**

(type text here)

**Body:**  
(type text here)



# TOWN OF LEDYARD

741 Colonel Ledyard  
Highway  
Ledyard, CT 06339-1511

---

**File #:** 26-0727

**Agenda Date:** 5/27/2026

**Agenda #:** 14.

---

## FINANCIAL BUSINESS REQUEST (FBR)

**Motion/Request:**

MOTION to appropriate and transfer the Board of Education's Fiscal Year 2024/2025 Audited Surplus in the amount of \$212,031 from Undesignated Fund Balance) to the newly established Board of Education Fund.

**Background:**

(type text here)

**Department Comment/Recommendation:**

(type text here)

**Finance Director Comment/Recommendation:**

(type text here)

**Mayor Comment/Recommendation:**

(type text here)

## Roxanne Maher

---

**From:** Gary St. Vil  
**Sent:** Tuesday, May 5, 2026 5:19 PM  
**To:** Jessica Buhle  
**Cc:** Roxanne Maher; jreguin@ledyard.net; Jason S. Hartling; Fred Allyn, III; Matthew Bonin; Town Council Group  
**Subject:** BOE Surplus Transfer & Reimbursement – Finance Committee Review  
**Attachments:** Board of Education Fiscal Year 2024-2025 Budget Surplus Transfer-ltr-2026-03-30.pdf; Finance Director response to BOE communication dated March 30 2026.pdf

Councilor Buhle,

Please have the Finance Committee review the attached correspondence from the Board of Education and the Finance Director regarding the FY24–25 surplus transfer and the Eversource reimbursement.

There appears to be a difference in how these funds are being treated from a process and statutory standpoint. I'd like the Committee to review and provide a recommendation on the appropriate path forward to ensure we are aligned and handling the funds correctly. This should include clarification on the proper handling of the surplus funds and reimbursement, and any required Council actions. The goal is to support the Board of Education's intent while ensuring we are following the proper municipal process.

Please let me know if you need any additional support.

Respectfully,

**Gary A. St. Vil**

Chairman, Ledyard Town Council  
741 Colonel Ledyard Highway  
Ledyard, CT 06339  
(860) 980-0656 | gsvil@ledyardct.org  
www.ledyardct.org



March 30, 2026

Ledyard Town Council  
% Mrs. Jessica Buell, Chair - Finance Committee  
Town of Ledyard  
741 Colonel Ledyard Highway  
Ledyard, CT 06339

Dear Chairman Buell,

The Board of Education at its September 9, 2025 authorized the transfer of the 2024-2025 fiscal year reserve amount to the Capital Non-Recurring account (CNR). The amount per the final audit results is \$212,301.

In addition, the Board of Education Finance Committee at its March 10, 2026 meeting, took formal action to direct the deposit of the check received from Eversource Energy for reimbursement of steam trap surveys for \$19,943 dated 12/02/2025 to the Board's CNR account. This reimbursement was budgeted as part of the anticipated cost. A copy of the check that was delivered to the town offices on January 8, 2026 is enclosed.

Please let me know if you have any questions. Thank you for your attention to this matter.

Sincerely,  
  
Jenn Reguin

Cc: Jason S. Hartling, Superintendent of Schools

CL+P - DISTRIBUTION DBA EVERSOURCE ENERGY

Bank of America Higher Standards

969526

115

51-44  
119 CT

DATE:  
12/03/2025

PAY Nineteen Thousand Nine Hundred Forty-Three Dollars & 00/100 US Dollars

USD: \$19,943.00

TO THE LEDYARD PUBLIC SCHOOLS  
ORDER OF 24 GALLUP HILL RD  
LEDYARD CT 06339 UNITED STATES

*John M. Moran*  
Authorized Signature

⑈0000969526⑈ ⑆011900445⑆ 00000070684⑈

CL+P - DISTRIBUTION DBA EVERSOURCE ENERGY  
PO BOX 5017, HARTFORD, CT 06102-5017

969526  
Date:12/02/2025

LEDYPUSC-000

VOICE DATE	INVOICE No	PO#	DISC AMT	CURR	PAYMENT AMT
7/28/2025	PB-128628		\$	USD	\$19,943.00
Pymt Comments: ATTN WAYNE DONALDSON. LEDYARD GALLUP HILL HS STEAM SURVEY CT25S02852777.					

Total: \$19,943.00

000154





Town of Ledyard  
Connecticut  
**FINANCE DEPARTMENT**  
741 Colonel Ledyard Highway  
Ledyard, CT 06339  
Tel: 860-464.3235

Finance Director  
Matthew Bonin

Assistant Finance Director  
Ian Stammel

April 22, 2026

Ledyard Town Council  
c/o Chairman Gary St. Vil  
741 Colonel Ledyard Hwy  
Ledyard, CT 06339

Chairman St. Vil,

I would like to share my comments in response to the letter from the Board of Education Chairman that was addressed to the Ledyard Town Council on March 30<sup>th</sup> 2026 and attached to the April 8<sup>th</sup> 2026 Town Council agenda.

Regarding the first item referencing the Board of Education FY 2024-2025 audit surplus of \$212,031 and the related transfer of the funds to the Board of Education Capital Non-Recurring (CNR) account, as I have stated on more than one occasion publicly, these funds cannot go directly in the Board of Education's CNR account as based on the legislation, these funds are not strictly capital in nature. Additionally, I had asked the auditor about this during the audit presentation at the finance committee meeting on February 4<sup>th</sup>, 2026. He agreed with my assertion. I would also like to point out that both the Superintendent and Board of Education chair were present at that meeting. The correct course of action is for the Council to authorize the appropriation and transfer of these funds to a new non-lapsing Board of Education fund that would be set up solely for the intended purposes of this legislation. If the Board of Education wishes to utilize these funds for capital purposes, they are certainly entitled to do that, but it would take Board action to move the funds from the new non-lapsing fund into the Board of Education CNR account as that is spelled out in the legislation.

Regarding the \$19,943 reimbursement from Eversource, the original expenditures took place in fiscal year 2024-2025. When the Board of Education finance office sent the check over to the Town finance department, there was a request to net it against the expenditure account that these funds were originally expensed out of in fiscal year 2024-2025. As that year was already closed out, that was not feasible. The check was deposited into the general fund

miscellaneous revenue account. I instructed the Board of Ed finance director that the best course of action would be to initiate a formal request to Town Council to transfer these funds into the Board of Education's CNR account. I have no issue with moving the funds, but it is going to require Town Council action to do so.

It should also be noted that per the Town Charter, as both of these items are non-budgeted appropriations, they will require Town Council action in order to be moved.

Sincerely,

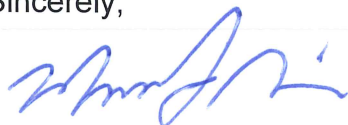
A handwritten signature in blue ink, appearing to read 'Matthew Bonin', written in a cursive style.

Matthew Bonin  
Director of Finance

Cc Fred B. Allyn III, Mayor



# TOWN OF LEDYARD

741 Colonel Ledyard  
Highway  
Ledyard, CT 06339-1511

---

**File #:** 26-0735

**Agenda Date:** 5/27/2026

**Agenda #:** 15.

---

## FINANCIAL BUSINESS REQUEST (FBR)

**Motion/Request:**

MOTION to transfer Eversource Reimbursement in the amount of \$19,943 from Undesignated Fund Balance to the Board of Education's Capital Non-Reoccurring Account.

**Background:**

(type text here)

**Department Comment/Recommendation:**

(type text here)

**Finance Director Comment/Recommendation:**

(type text here)

**Mayor Comment/Recommendation:**

(type text here)

## Roxanne Maher

---

**From:** Gary St. Vil  
**Sent:** Tuesday, May 5, 2026 5:19 PM  
**To:** Jessica Buhle  
**Cc:** Roxanne Maher; jreguin@ledyard.net; Jason S. Hartling; Fred Allyn, III; Matthew Bonin; Town Council Group  
**Subject:** BOE Surplus Transfer & Reimbursement – Finance Committee Review  
**Attachments:** Board of Education Fiscal Year 2024-2025 Budget Surplus Transfer-ltr-2026-03-30.pdf; Finance Director response to BOE communication dated March 30 2026.pdf

Councilor Buhle,

Please have the Finance Committee review the attached correspondence from the Board of Education and the Finance Director regarding the FY24–25 surplus transfer and the Eversource reimbursement.

There appears to be a difference in how these funds are being treated from a process and statutory standpoint. I'd like the Committee to review and provide a recommendation on the appropriate path forward to ensure we are aligned and handling the funds correctly. This should include clarification on the proper handling of the surplus funds and reimbursement, and any required Council actions. The goal is to support the Board of Education's intent while ensuring we are following the proper municipal process.

Please let me know if you need any additional support.

Respectfully,

**Gary A. St. Vil**

Chairman, Ledyard Town Council  
741 Colonel Ledyard Highway  
Ledyard, CT 06339  
(860) 980-0656 | gsvil@ledyardct.org  
www.ledyardct.org



# Ledyard Public Schools

Administrative Offices

March 30, 2026

Ledyard Town Council  
% Mrs. Jessica Buell, Chair - Finance Committee  
Town of Ledyard  
741 Colonel Ledyard Highway  
Ledyard, CT 06339

Dear Chairman Buell,

The Board of Education at its September 9, 2025 authorized the transfer of the 2024-2025 fiscal year reserve amount to the Capital Non-Recurring account (CNR). The amount per the final audit results is \$212,301.

In addition, the Board of Education Finance Committee at its March 10, 2026 meeting, took formal action to direct the deposit of the check received from Eversource Energy for reimbursement of steam trap surveys for \$19,943 dated 12/02/2025 to the Board's CNR account. This reimbursement was budgeted as part of the anticipated cost. A copy of the check that was delivered to the town offices on January 8, 2026 is enclosed.

Please let me know if you have any questions. Thank you for your attention to this matter.

Sincerely,  
  
Jenn Reguin

Cc: Jason S. Hartling, Superintendent of Schools

CL+P - DISTRIBUTION DBA EVERSOURCE ENERGY

Bank of America Higher Standards

969526

51-44  
119 CT

DATE:  
12/03/2025

121

PAY Nineteen Thousand Nine Hundred Forty-Three Dollars & 00/100 US Dollars

USD: \$19,943.00

TO THE LEDYARD PUBLIC SCHOOLS  
ORDER OF 24 GALLUP HILL RD  
LEDYARD CT 06339 UNITED STATES

*John M. Moran*  
Authorized Signature

⑈0000969526⑈ ⑆011900445⑆ 00000070684⑈

CL+P - DISTRIBUTION DBA EVERSOURCE ENERGY  
PO BOX 5017, HARTFORD, CT 06102-5017

969526  
Date:12/02/2025

LEDYPUSC-000

VOICE DATE	INVOICE No	PO#	DISC AMT	CURR	PAYMENT AMT
7/28/2025	PB-128628		\$	USD	\$19,943.00
Pymt Comments: ATTN WAYNE DONALDSON. LEDYARD GALLUP HILL HS STEAM SURVEY CT25S02852777.					

Total: \$19,943.00

000154





Town of Ledyard  
Connecticut  
**FINANCE DEPARTMENT**  
741 Colonel Ledyard Highway  
Ledyard, CT 06339  
Tel: 860-464.3235

Finance Director  
Matthew Bonin

Assistant Finance Director  
Ian Stammel

April 22, 2026

Ledyard Town Council  
c/o Chairman Gary St. Vil  
741 Colonel Ledyard Hwy  
Ledyard, CT 06339

Chairman St. Vil,

I would like to share my comments in response to the letter from the Board of Education Chairman that was addressed to the Ledyard Town Council on March 30<sup>th</sup> 2026 and attached to the April 8<sup>th</sup> 2026 Town Council agenda.

Regarding the first item referencing the Board of Education FY 2024-2025 audit surplus of \$212,031 and the related transfer of the funds to the Board of Education Capital Non-Recurring (CNR) account, as I have stated on more than one occasion publicly, these funds cannot go directly in the Board of Education's CNR account as based on the legislation, these funds are not strictly capital in nature. Additionally, I had asked the auditor about this during the audit presentation at the finance committee meeting on February 4<sup>th</sup>, 2026. He agreed with my assertion. I would also like to point out that both the Superintendent and Board of Education chair were present at that meeting. The correct course of action is for the Council to authorize the appropriation and transfer of these funds to a new non-lapsing Board of Education fund that would be set up solely for the intended purposes of this legislation. If the Board of Education wishes to utilize these funds for capital purposes, they are certainly entitled to do that, but it would take Board action to move the funds from the new non-lapsing fund into the Board of Education CNR account as that is spelled out in the legislation.

Regarding the \$19,943 reimbursement from Eversource, the original expenditures took place in fiscal year 2024-2025. When the Board of Education finance office sent the check over to the Town finance department, there was a request to net it against the expenditure account that these funds were originally expensed out of in fiscal year 2024-2025. As that year was already closed out, that was not feasible. The check was deposited into the general fund

miscellaneous revenue account. I instructed the Board of Ed finance director that the best course of action would be to initiate a formal request to Town Council to transfer these funds into the Board of Education's CNR account. I have no issue with moving the funds, but it is going to require Town Council action to do so.

It should also be noted that per the Town Charter, as both of these items are non-budgeted appropriations, they will require Town Council action in order to be moved.

Sincerely,

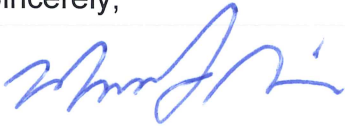
A handwritten signature in blue ink, appearing to read 'Matthew Bonin', written in a cursive style.

Matthew Bonin  
Director of Finance

Cc Fred B. Allyn III, Mayor



# TOWN OF LEDYARD

741 Colonel Ledyard  
Highway  
Ledyard, CT 06339-1511

---

**File #:** 26-0737

**Agenda Date:** 5/27/2026

**Agenda #:** 16.

---

AGENDA REQUEST  
GENERAL DISCUSSION ITEM

**Subject:**

Discussion regarding the Town Council's 2026 Summer Meeting schedule.

**Background:**

(type text here)

**Department Comment/Recommendation:**

(type text here)