

MAP REFERENCES

- "RIGHT OF WAY AND TRACK MAP OPERATED BY THE NORWICH AND WORCESTER R.R. CO. OPERATED BY THE NEW YORK NEW HAVEN AND HARTFORD R.R. CO. FROM WORCESTER TO GROTON STATION 3379+20 TO STATION 3405+60 TOWN OF LEDYARD, STATE OF CONN." SCALE 1"=50' DATE: JUNE 30, 1915 REVISED THROUGH OCTOBER 9, 1947, OFFICE OF VALUATION ENGINEER, BOSTON MASS. MAP NO. V.5063 / 129.
- "RIGHT OF WAY AND TRACK MAP OPERATED BY THE NORWICH AND WORCESTER R.R. CO. OPERATED BY THE NEW YORK NEW HAVEN AND HARTFORD R.R. CO. FROM WORCESTER TO GROTON STATION 3405+60 TO STATION 32+00 TOWN OF LEDYARD, STATE OF CONN." SCALE 1"=50' DATE: JUNE 30, 1915, OFFICE OF VALUATION ENGINEER, BOSTON MASS. MAP NO. V.5063 / 130.
- "RIGHT OF WAY AND TRACK MAP OPERATED BY THE NORWICH AND WORCESTER R.R. CO. OPERATED BY THE NEW YORK NEW HAVEN AND HARTFORD R.R. CO. FROM WORCESTER TO GROTON STATION 32+00 TO STATION 58+40 TOWN OF LEDYARD, STATE OF CONN." SCALE 1"=50' DATE: JUNE 30, 1915 REVISED THROUGH APRIL 11, 1951, OFFICE OF VALUATION ENGINEER, BOSTON MASS. MAP NO. V.5063 / 131.
- "RIGHT OF WAY AND TRACK MAP OPERATED BY THE NORWICH AND WORCESTER R.R. CO. OPERATED BY THE NEW YORK NEW HAVEN AND HARTFORD R.R. CO. FROM WORCESTER TO GROTON STATION 58+40 TO STATION 84+80 TOWN OF LEDYARD, STATE OF CONN." SCALE 1"=50' DATE: JUNE 30, 1915 REVISED THROUGH APRIL 11, 1951, OFFICE OF VALUATION ENGINEER, BOSTON MASS. MAP NO. V.5063 / 132.

MAP REFERENCES-CONTINUED

- "NORWICH AND WORCESTER RAILROAD REAL ESTATE & RIGHT OF WAY DEPARTMENT LAND IN LEDYARD, CONN. TO BE CONVEYED TO THE DOW CHEMICAL COMPANY" SCALE 1"=200' DATE: SEPTEMBER 1950 REVISED THROUGH OCTOBER 1950, ON FILE AS MAP NO. BA.
- "LOCATION OF THE RIGHT OF WAY OF THE CONNECTICUT LIGHT & POWER COMPANY ACROSS THE PROPERTY OF THE DOW CHEMICAL COMPANY, TOWN OF LEDYARD, COUNTY OF NEW LONDON, STATE OF CONNECTICUT" SCALE 1"=200' DATE: APRIL 17, 1951.
- "MAP OF PROPERTY OWNED BY THE DOW CHEMICAL COMPANY LOCATED AT ALLYN'S POINT ON THE WEST SIDE OF ROUTE 12 AND EAST OF THE NEW YORK NEW HAVEN & HARTFORD RAILROAD CO. LEDYARD, CONN." SCALE: 1"=100' DATE: JULY 1952 REVISED AUGUST 1953, G.L. BILDERBECK CONSULTING ENGINEERS, NEW LONDON, CONN.
- "MAP SHOWING PROPERTY OWNED BY DOW CHEMICAL COMPANY, ALLYN'S POINT, LEDYARD, CONN." SCALE: 1"=100' DATE: DECEMBER 1953, G.L. BILDERBECK, CONSULTING ENGINEERS, NEW LONDON, CONN. ON FILE AS MAP NO. 43A.

MAP REFERENCES-CONTINUED

- "CONNECTICUT STATE HIGHWAY DEPARTMENT RIGHT OF WAY MAP TOWN OF LEDYARD NORWICH-GROTON ROAD FROM ALLYN'S BROOK NORTHERLY TO LEDYARD-PRESTON TOWN LINE" SCALE 1"=40' DATE: NOVEMBER 5, 1957, SHEETS 1 THROUGH 3 OF 9 PROJECT NUMBER: 71-16. THESE MAPS SUPERSEDE PROJECT 71-05, SHEET 3 REVISED AUGUST 25, 1967.
- "CONNECTICUT STATE HIGHWAY DEPARTMENT RIGHT OF WAY MAP TOWN OF LEDYARD GROTON-NORWICH ROAD GALES FERRY ROAD TO LEDYARD-PRESTON TOWN LINE" SCALE 1"=40' DATE: NOVEMBER 5, 1957, SHEETS 1 THROUGH 4 OF 4 PROJECT NUMBER 71-15. THESE MAPS SUPERSEDE PROJECT 71-04, SHEET 1 REVISED THROUGH MAY 17, 2004.
- "PLAN SHOWING LANDS NOW AND FORMERLY OF H. WINTROP HURLBUTT LEDYARD, CONNECTICUT" SCALE 1"=100' DATE: OCTOBER 1964, GEORGE H. DIETER, LAND SURVEYOR, ON FILE AS MAP # 226.
- "PLAN OF PROPERTY TO BE CONVEYED TO THE TOWN OF LEDYARD BY THE DOW CHEMICAL COMPANY, TOWN OF LEDYARD, CONN." SCALE: 1"=100' DATE: APRIL 1972, CHANDLER, PALMER & KING, NORWICH, CONN.

MAP REFERENCES-CONTINUED

- "PLAN SHOWING PARCELS OF LAND WITH BUILDINGS PROPERTY OF JAMES L. LEWIS AND ALICE L. LEWIS, FENWAY AT WEST END CHAPMAN LANE LEDYARD, CONNECTICUT" SCALE 1"=20' DATE: JUNE 1976, GEORGE H. DIETER, LAND SURVEYOR, ON FILE AS MAP # 672.
- "TOPOGRAPHICAL PLAN, PLAN OF A PORTION OF DOW CHEMICAL CO. ALLYN'S POINT PLANT GALES FERRY, CONN." SCALE: 1"=40' DATE: JULY 9, 1984 REVISIONS THROUGH AUGUST 28, 1984, CHANDLER, PALMER & KING, NORWICH, CONN.
- "MONUMENTED PROPERTY SURVEY MAP DEPICTING LAND OF GALES FERRY MARINA, INC. A PORTION OF LAND OF JAMES L. LEWIS AND LUCILLE A. LUPINACCO, CHAPMAN LANE, GALES FERRY, LEDYARD, CONNECTICUT" SCALE: 1"=40' DATE: MARCH 26, 1994 REVISED APRIL 19, 1994, DAVID L. STEIN, LAND SURVEYOR, WESTBROOK, CONNECTICUT, ON FILE AS MAP #1753.
- "COMPILATION PLAN MAP SHOWING EASEMENT AREA TO BE GRANTED TO THE YANKEE GAS SERVICES COMPANY ACROSS THE PROPERTY OF DOW CHEMICAL COMPANY (ALLYN'S POINT PLANT) #1761 ROUTE 12 GALES FERRY-LEDYARD CONNECTICUT SCALE: 1"=60' SHEET 1 OF 1 DATE: 03-04-2010 YANKEE FILE #00048, BY CME ASSOCIATES, INC. ON FILE AS MAP #2629.

NOTE
THE MATHEMATICAL CLOSING LINE FROM POINT "A" TO POINT "B" IS NORTH 61°15'22" EAST 743.02 FEET

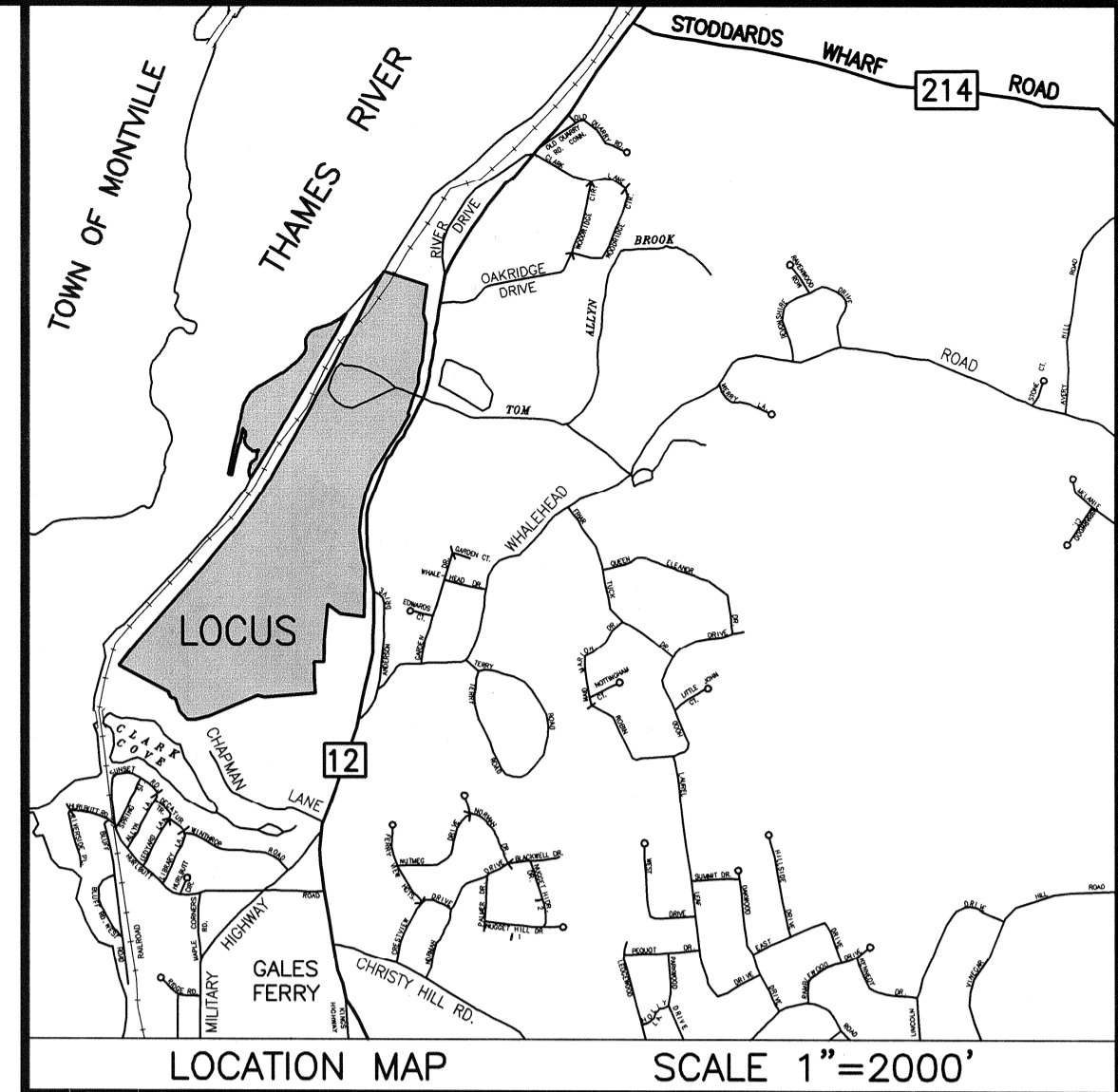
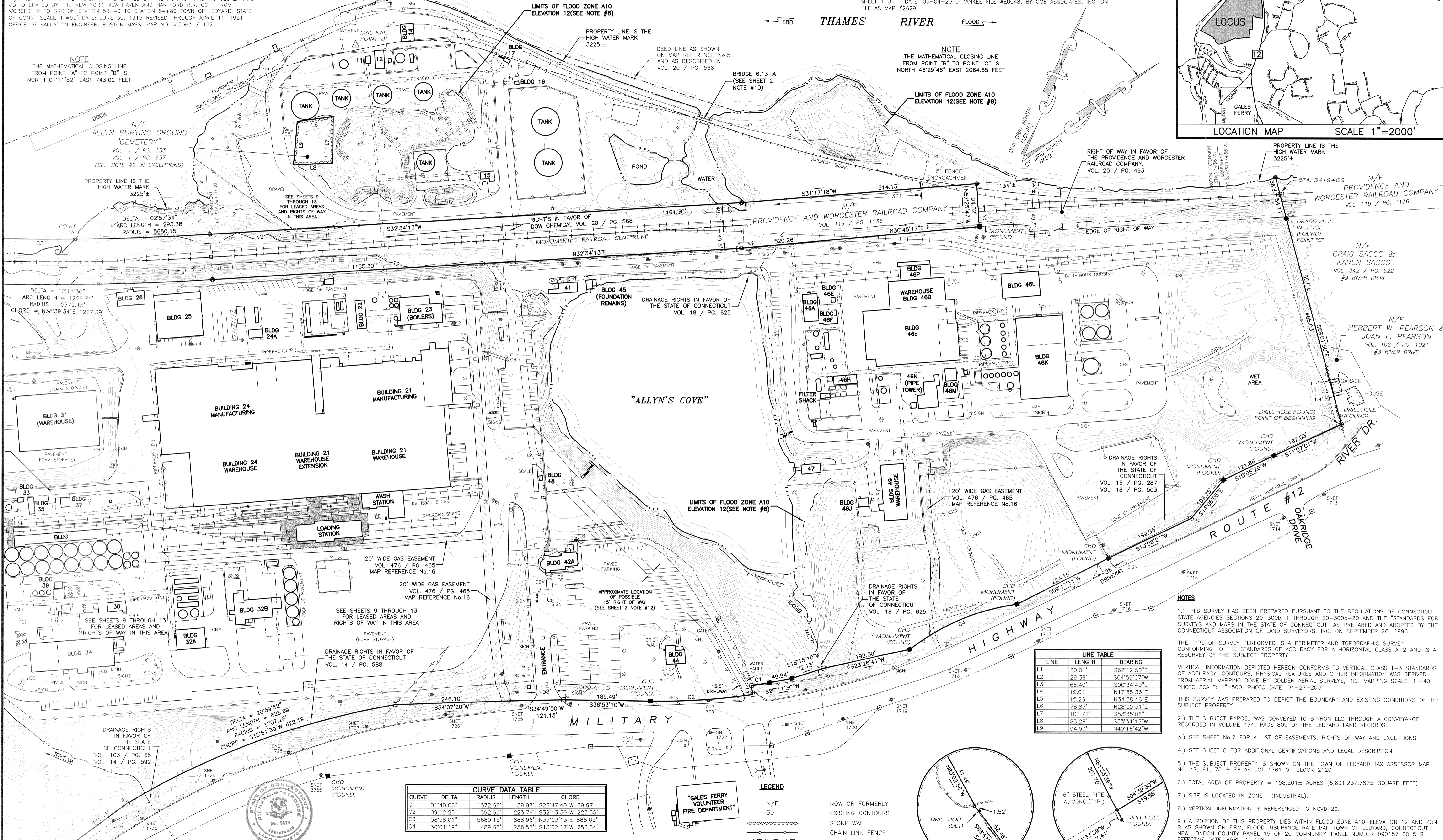

QUALITY CONTROL CERTIFICATION

GROUP	REVIEWED	DATE
PROJECT MANAGER		
SURVEY		

TO MY KNOWLEDGE AND BELIEF, THIS MAP IS SUBSTANTIALLY CORRECT AS NOTED HEREON.

RICHARD H. STROUSE, L.S. #9679

CURVE DATA TABLE

CURVE	DELTA	RADIUS	LENGTH	CHORD
C1	01°40'06"	1372.69'	39.97'	526'47'40" 39.97'
C2	09°12'25"	1392.69'	223.79'	532'13'30" 223.55'
C3	08°58'01"	5680.15'	888.96'	N37°03'13"E 888.05'
C4	30°01'19"	489.65'	256.57'	S13°02'17"W 253.64'

LEGEND

- N/F NOW OR FORMERLY EXISTING CONTOURS
- EXISTING WALL
- CHAIN LINK FENCE
- LEDGE
- LIGHT POLE
- UTILITY POLE
- MONUMENT NOT FOUND
- BOUNDARY POINT

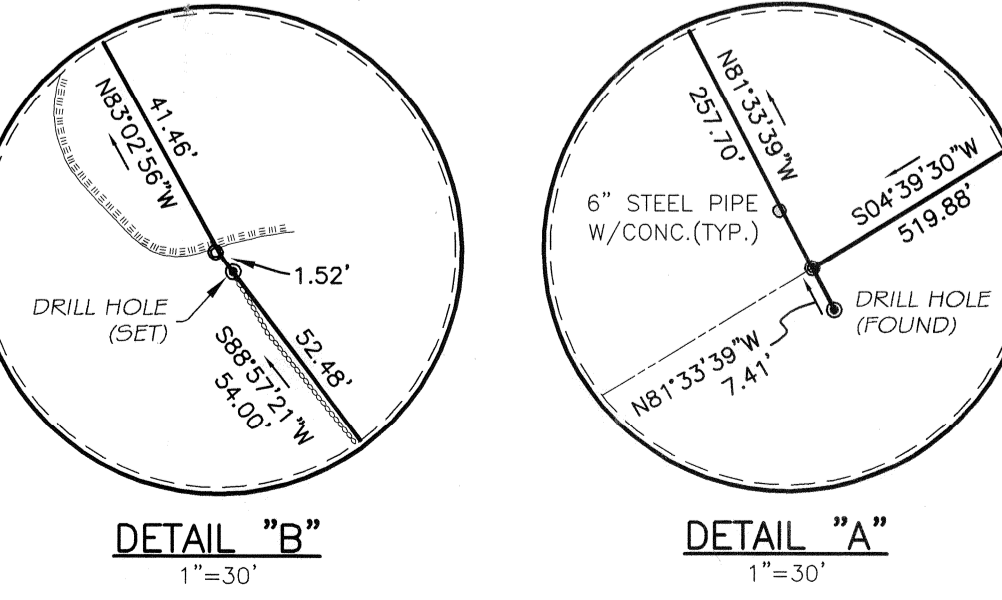

LINE TABLE

LINE	LENGTH	BEARING
L1	20.01'	S62°12'50"E
L2	29.38'	S04°59'07"W
L3	66.40'	S00°34'40"E
L4	19.01'	N17°55'36"E
L5	15.23'	N34°38'46"E
L6	78.87'	N28°09'31"E
L7	101.72'	S53°35'08"E
L8	85.28'	S33°34'13"W
L9	94.90'	N49°16'42"W

- NOTES**
- THIS SURVEY HAS BEEN PREPARED PURSUANT TO THE REGULATIONS OF CONNECTICUT STATE AGENCIES SECTIONS 20-300b-1 THROUGH 20-300b-20 AND THE STANDARDS FOR SURVEYS AND MAPS IN THE STATE OF CONNECTICUT AS PREPARED AND ADOPTED BY THE CONNECTICUT ASSOCIATION OF LAND SURVEYORS, INC. ON SEPTEMBER 26, 1996.
 - THE TYPE OF SURVEY PERFORMED IS A PERIMETER AND TOPOGRAPHIC SURVEY CONFORMING TO THE STANDARDS OF ACCURACY FOR A HORIZONTAL CLASS A-2 AND IS A RESURVEY OF THE SUBJECT PROPERTY.
 - VERTICAL INFORMATION DEPICTED HEREON CONFORMS TO VERTICAL CLASS T-3 STANDARDS OF ACCURACY. CONTOURS, PHYSICAL FEATURES AND OTHER INFORMATION WAS DERIVED FROM AERIAL MAPPING DONE BY GOLDEN AERIAL SURVEYS, INC. MAPPING SCALE: 1"=40' PHOTO SCALE: 1"=500' PHOTO DATE: 04-27-2001
 - THIS SURVEY WAS PREPARED TO DEPICT THE BOUNDARY AND EXISTING CONDITIONS OF THE SUBJECT PROPERTY.
 - THE SUBJECT PARCEL WAS CONVEYED TO STYRON LLC THROUGH A CONVEYANCE RECORDED IN VOLUME 474, PAGE 809 OF THE LEDYARD LAND RECORDS.
 - SEE SHEET NO.2 FOR A LIST OF EASEMENTS, RIGHTS OF WAY AND EXCEPTIONS.
 - SEE SHEET 8 FOR ADDITIONAL CERTIFICATIONS AND LEGAL DESCRIPTION.
 - THE SUBJECT PROPERTY IS SHOWN ON THE TOWN OF LEDYARD TAX ASSESSOR MAP NO. 47, 61, 75 & 76 AS LOT 1761 OF BLOCK 2120
 - TOTAL AREA OF PROPERTY = 158.201± ACRES (6,891,237.787± SQUARE FEET).
 - SITE IS LOCATED IN ZONE I (INDUSTRIAL).
 - VERTICAL INFORMATION IS REFERENCED TO NGVD 29.
 - A PORTION OF THIS PROPERTY LIES WITHIN FLOOD ZONE A10-ELEVATION 12 AND ZONE B AS SHOWN ON FIRM, FLOOD INSURANCE RATE MAP TOWN OF LEDYARD, CONNECTICUT NEW LONDON COUNTY PANEL 15 OF 20 CME ASSOCIATES, INC. THE SIZE, LOCATION AND EXISTENCE OF ALL SUCH FEATURES MUST BE FIELD DETERMINED AND VERIFIED BY THE APPROPRIATE AUTHORITIES PRIOR TO CONSTRUCTION. CALL BEFORE YOU DIG 1-800-922-4455.

CME Associates, Inc.

CME

32 Crabtree Lane, Woodstock, CT 06281
55 Main Street, Suite 340 Norwich, CT 06360
333 East River Drive, East Hartford, CT 06108
50 Elm Street, Southbridge, MA 01550
www.cmeengineering.com
Phone 888-291-3227

PROPERTY AND TOPOGRAPHIC SURVEY
PREPARED FOR
STYRON LLC
"ALLYN'S POINT PLANT"
#1737 & 1761 MILITARY HIGHWAY - ROUTE 12, GALES FERRY
LEDYARD, CONNECTICUT

REVISIONS

NO.	DATE	DESCRIPTION	BY

JOB DATA

PROJECT	2010063.DWG
BOOK NO.	4173
DESIGNED	
DRAWN	
CHECKED	
RHS	
CADD FILE	2010063_CB_4-21-2010
FILE	2010063_BND.dwg

DATE: SEPT. 2, 2010
SCALE: 1" = 100'
PROJECT: #2010063

SHEET 1 OF 13

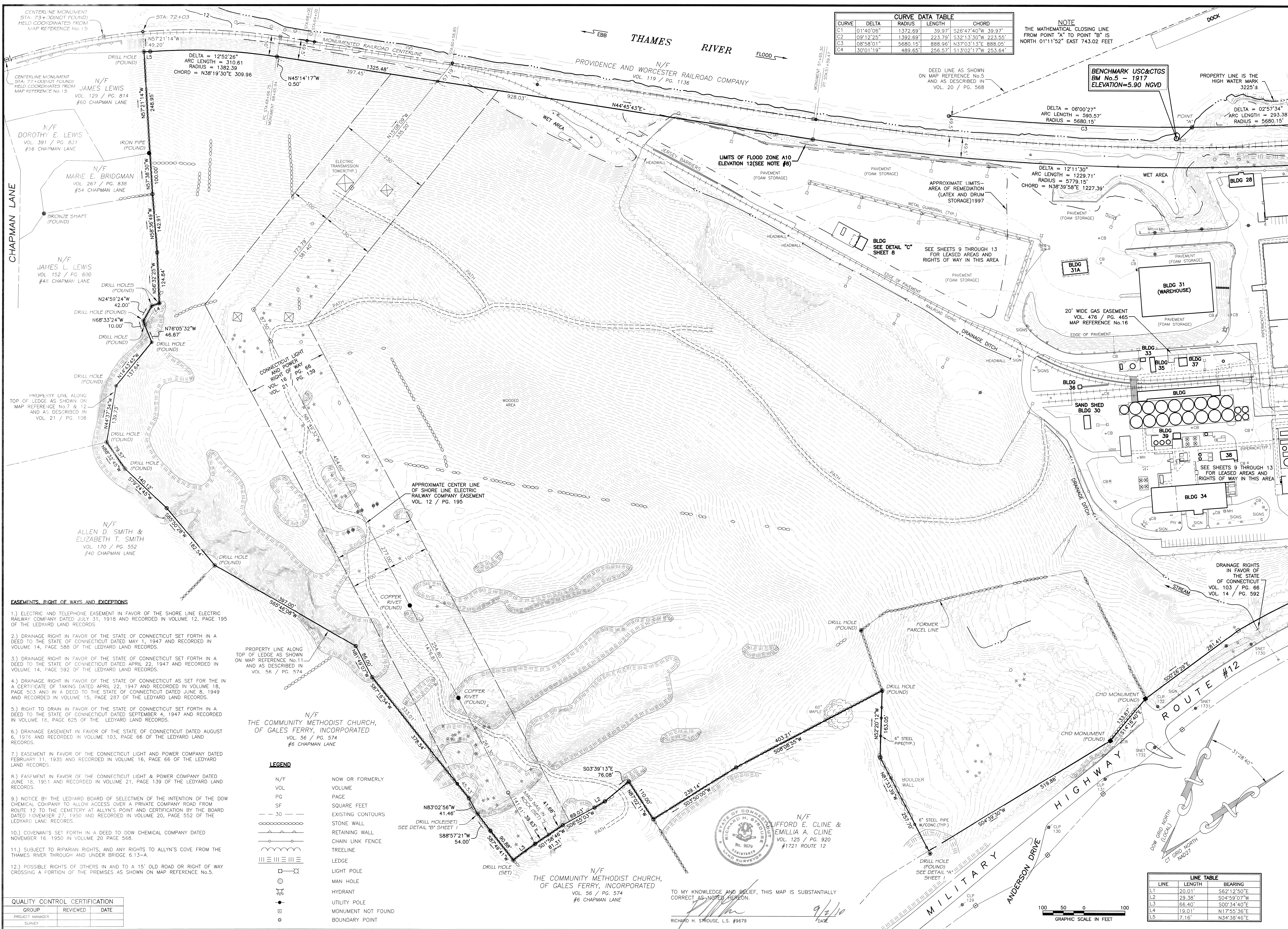

CURVE	DELTA	RADIUS	LENGTH	CHORD
C1	01°40'08"	1372.69'	39.97'	526°47'40"W 39.97'
C2	09°12'25"	1392.69'	223.79'	532°13'30"W 223.55'
C3	08°58'01"	5680.15'	888.96'	N37°03'13"E 888.00'
C4	30°01'19"	489.65'	256.57'	S13°02'17"W 253.64'

NOTE
THE MATHEMATICAL CLOSING LINE FROM POINT "A" TO POINT "B" IS NORTH 01°11'52" EAST 743.02 FEET

BENCHMARK USC&CTGS
BM No.5 - 1917
ELEVATION=5.90 NGVD

DEED LINE AS SHOWN ON MAP REFERENCE No.5 AND AS DESCRIBED IN VOL. 20 / PG. 568

DELTA = 06°00'27"
ARC LENGTH = 595.57'
RADIUS = 5680.15'

DELTA = 02°57'34"
ARC LENGTH = 293.38'
RADIUS = 5680.15'

DELTA = 12°11'30"
ARC LENGTH = 1229.71'
RADIUS = 5779.15'
CHORD = N38°39'58"E 1227.39'

BLDG 31A
SEE SHEETS 9 THROUGH 13 FOR LEASED AREAS AND RIGHTS OF WAY IN THIS AREA

20' WIDE GAS EASEMENT
VOL. 476 / PG. 465
MAP REFERENCE No.16

SEE SHEETS 9 THROUGH 13 FOR LEASED AREAS AND RIGHTS OF WAY IN THIS AREA

DRAINAGE RIGHTS IN FAVOR OF THE STATE OF CONNECTICUT
VOL. 103 / PG. 66
VOL. 14 / PG. 592

APPROXIMATE CENTER LINE OF SHORE LINE ELECTRIC RAILWAY COMPANY EASEMENT
VOL. 12 / PG. 195

EASEMENTS, RIGHT OF WAYS AND EXCEPTIONS

- 1.) ELECTRIC AND TELEPHONE EASEMENT IN FAVOR OF THE SHORE LINE ELECTRIC RAILWAY COMPANY DATED JULY 31, 1918 AND RECORDED IN VOLUME 12, PAGE 195 OF THE LEDYARD LAND RECORDS.
- 2.) DRAINAGE RIGHT IN FAVOR OF THE STATE OF CONNECTICUT SET FORTH IN A DEED TO THE STATE OF CONNECTICUT DATED MAY 1, 1947 AND RECORDED IN VOLUME 14, PAGE 588 OF THE LEDYARD LAND RECORDS.
- 3.) DRAINAGE RIGHT IN FAVOR OF THE STATE OF CONNECTICUT SET FORTH IN A DEED TO THE STATE OF CONNECTICUT DATED APRIL 22, 1947 AND RECORDED IN VOLUME 14, PAGE 592 OF THE LEDYARD LAND RECORDS.
- 4.) DRAINAGE RIGHT IN FAVOR OF THE STATE OF CONNECTICUT AS SET FORTH IN A CERTIFICATE OF TAKING DATED APRIL 22, 1947 AND RECORDED IN VOLUME 18, PAGE 503 AND IN A DEED TO THE STATE OF CONNECTICUT DATED JUNE 8, 1949 AND RECORDED IN VOLUME 15, PAGE 287 OF THE LEDYARD LAND RECORDS.
- 5.) RIGHT TO DRAIN IN FAVOR OF THE STATE OF CONNECTICUT SET FORTH IN A DEED TO THE STATE OF CONNECTICUT DATED SEPTEMBER 4, 1947 AND RECORDED IN VOLUME 18, PAGE 625 OF THE LEDYARD LAND RECORDS.
- 6.) DRAINAGE EASEMENT IN FAVOR OF THE STATE OF CONNECTICUT DATED AUGUST 6, 1976 AND RECORDED IN VOLUME 103, PAGE 66 OF THE LEDYARD LAND RECORDS.
- 7.) EASEMENT IN FAVOR OF THE CONNECTICUT LIGHT AND POWER COMPANY DATED FEBRUARY 11, 1935 AND RECORDED IN VOLUME 16, PAGE 66 OF THE LEDYARD LAND RECORDS.
- 8.) EASEMENT IN FAVOR OF THE CONNECTICUT LIGHT & POWER COMPANY DATED JUNE 18, 1951 AND RECORDED IN VOLUME 21, PAGE 139 OF THE LEDYARD LAND RECORDS.
- 9.) NOTICE BY THE LEDYARD BOARD OF SELECTMEN OF THE INTENTION OF THE DOW CHEMICAL COMPANY TO ALLOW ACCESS OVER A PRIVATE COMPANY ROAD FROM ROUTE 12 TO THE CEMETERY AT ALLYN'S POINT AND CERTIFICATION BY THE BOARD DATED NOVEMBER 27, 1950 AND RECORDED IN VOLUME 20, PAGE 552 OF THE LEDYARD LAND RECORDS.
- 10.) COVENANTS SET FORTH IN A DEED TO DOW CHEMICAL COMPANY DATED NOVEMBER 16, 1950 IN VOLUME 20 PAGE 568.
- 11.) SUBJECT TO RIPARIAN RIGHTS, AND ANY RIGHTS TO ALLYN'S COVE FROM THE THAMES RIVER THROUGH AND UNDER BRIDGE 6.13-A.
- 12.) POSSIBLE RIGHTS OF OTHERS IN AND TO A 15' OLD ROAD OR RIGHT OF WAY CROSSING A PORTION OF THE PREMISES AS SHOWN ON MAP REFERENCE No.5.

PROPERTY LINE ALONG TOP OF LEDGE AS SHOWN ON MAP REFERENCE No.11 AND AS DESCRIBED IN VOL. 56 / PG. 574

N/F THE COMMUNITY METHODIST CHURCH, OF GALES FERRY, INCORPORATED
VOL. 56 / PG. 574
#6 CHAPMAN LANE

LEGEND

N/F	NOW OR FORMERLY
VOL	VOLUME
PG	PAGE
SF	SQUARE FEET
---	EXISTING CONTOURS
=====	STONE WALL
-----	RETAINING WALL
-----	CHAIN LINK FENCE
-----	TREELINE
=====	LEDGE
○	LIGHT POLE
○	MAN HOLE
○	HYDRANT
○	UTILITY POLE
○	MONUMENT NOT FOUND
○	BOUNDARY POINT

QUALITY CONTROL CERTIFICATION

GROUP	REVIEWED	DATE
PROJECT MANAGER		
SURVEY		

N/F THE COMMUNITY METHODIST CHURCH, OF GALES FERRY, INCORPORATED
VOL. 56 / PG. 574
#6 CHAPMAN LANE

N/F RICHARD E. CLINE & EMILIA A. CLINE
VOL. 125 / PG. 920
#1721 ROUTE 12

TO MY KNOWLEDGE AND BELIEF, THIS MAP IS SUBSTANTIALLY CORRECT AS NOTED HEREON.
RICHARD H. STROUSE, L.S. #9679
DATE: 9/2/10

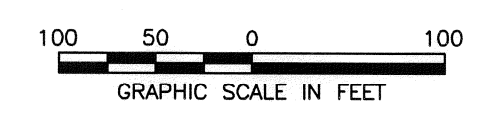

LINE TABLE

LINE	LENGTH	BEARING
L1	20.01'	S62°12'50"E
L2	29.38'	S04°59'07"W
L3	66.40'	S00°34'40"E
L4	19.01'	N17°55'36"E
L5	7.16'	N34°39'46"E

CME Associates, Inc.

CME

32 Crabtree Lane, Woodstock, CT 06281
55 Main Street, Suite 340 Norwich, CT 06360
333 East River Drive, East Hartford, CT 06108
50 Elm Street, Southington, MA 01550
Phone 888-291-3227
www.cmeengineering.com

PROPERTY AND TOPOGRAPHIC SURVEY
PREPARED FOR
STYRON LLC
"ALLYN'S POINT PLANT"
#1737 & 1761 MILITARY HIGHWAY - ROUTE 12, GALES FERRY
LEDYARD, CONNECTICUT

JOB DATA

PROJECT	2010063 DOW
BOOK NO.	4173
DESIGNED	CB
DRAWN	CB
CHECKED	RHS
CADD FILE	2010063 CB 4-21-2010
FILE	2010063_BND.dwg

REVISIONS

NO.	DATE	DESCRIPTION	BY

DATE: SEPT. 2, 2010
SCALE: 1" = 100'
PROJECT: #2010063

SHEET
2 OF 13