

APPROVED BY THE LEDYARD PLANNING AND ZONING COMMISSION AS TO THE COMPLIANCE WITH THE REGULATIONS GOVERNING THE SUBDIVISION OF LAND. ALL IMPROVEMENTS SHALL BE COMPLETED BY \_\_\_\_\_ DATE \_\_\_\_\_

CHAIRMAN OR SECRETARY \_\_\_\_\_ DATE \_\_\_\_\_

EROSION AND SEDIMENT CONTROL PLAN CERTIFIED BY VOTE OF \_\_\_\_\_ DATE \_\_\_\_\_ THE LEDYARD PLANNING AND ZONING COMMISSION ON \_\_\_\_\_ DATE \_\_\_\_\_

LOT NUMBERS ASSIGNED BY THE ASSESSOR \_\_\_\_\_ DATE \_\_\_\_\_

ASSESSOR \_\_\_\_\_ DATE \_\_\_\_\_

IHWC APPLICATION# \_\_\_\_\_ DATE \_\_\_\_\_

APPROVED, \_\_\_\_\_ DATE \_\_\_\_\_

NO PERMIT NECESSARY. (NOT WITHIN A REGULATED AREA) NOT APPLICABLE AT THIS TIME. (WITHIN A REGULATED AREA; NO REGULATED ACTIVITY PROPOSED AT THIS TIME.)

WETLANDS OFFICER \_\_\_\_\_ DATE \_\_\_\_\_

APPROVED BY THE DIRECTOR OF PUBLIC WORKS OR THE TOWN ENGINEER FOR PUBLIC WAY LAYOUT. \_\_\_\_\_ DATE \_\_\_\_\_

PUBLIC WORKS DIRECTOR/TOWN ENGINEER \_\_\_\_\_ DATE \_\_\_\_\_

EROSION AND SEDIMENT CONTROL PLAN CERTIFIED BY VOTE OF THE LEDYARD PLANNING AND ZONING COMMISSION \_\_\_\_\_ DATE \_\_\_\_\_

CHAIRMAN OR SECRETARY OF THE LEDYARD PLANNING AND ZONING COMMISSION \_\_\_\_\_ DATE \_\_\_\_\_

STREET ADDRESS	TOTAL AREA
1	12,481 Sq. Ft. 0.29 ACRES
2	24,444 Sq. Ft. 0.56 ACRES
3	10,439 Sq. Ft. 0.24 ACRES
4	13,910 Sq. Ft. 0.32 ACRES
5	11,762 Sq. Ft. 0.27 ACRES
6	14,542 Sq. Ft. 0.33 ACRES
7	10,561 Sq. Ft. 0.24 ACRES
8	14,287 Sq. Ft. 0.33 ACRES
9	10,201 Sq. Ft. 0.23 ACRES
10	12,819 Sq. Ft. 0.29 ACRES
11	11,508 Sq. Ft. 0.26 ACRES
12	15,917 Sq. Ft. 0.37 ACRES
13	12,308 Sq. Ft. 0.28 ACRES
14	9,756 Sq. Ft. 0.22 ACRES
15	12,575 Sq. Ft. 0.29 ACRES
16	20,973 Sq. Ft. 0.48 ACRES
17	11,456 Sq. Ft. 0.26 ACRES
18	14,762 Sq. Ft. 0.34 ACRES

**LEGEND**

- ○ ○ ○ ○ ○ ○ ○ ○ ○ STONE WALL
- — — — — PROPERTY LINE
- — — — — STREET LINE
- DH FND DRILL HOLE FOUND
- IP FND IRON PIPE FOUND
- DRILL HOLE OR REBAR TO BE SET
- MONUMENT OR DRILL HOLE TO BE SET
- ⑦ CURVE TABLE NUMBER
- UTILITY POLE
- ▨ ACCESS/UTILITY EASEMENT
- ⑧ STREET ADDRESS

THE STONE WALLS AND/OR FENCES SHOWN AS BOUNDARIES MAY HAVE IRREGULARITIES OF COURSE BETWEEN PRINCIPAL POINTS OF COURSE INDICATED.

THE WORD "CERTIFY" IS UNDERSTOOD TO BE AN EXPRESSION OF THE PROFESSIONAL OPINION BY THE LAND SURVEYOR WHICH IS BASED ON HIS OR HER BEST KNOWLEDGE, INFORMATION AND BELIEF. AS SUCH IT CONSTITUTES NEITHER GUARANTEE OR WARRANTY.

NOTE: BOUNDARY LINES OF ADJOINING PROPERTIES ARE SHOWN FOR GENERAL INFORMATION PURPOSES ONLY AND ARE NOT TO BE CONSTRUED AS BEING ACCURATELY LOCATED OR DEPICTED.

© THIS DRAWING IS THE PROPERTY OF THE LAND SURVEYOR. THIS PLAN AND REPRODUCTIONS, ADDITIONS OR REVISIONS OF THIS PLAN ARE NOT VALID WITHOUT THE EMBOSSED SEAL AND SIGNATURE OF THE LAND SURVEYOR WHO PREPARED THIS PLAN. JOB# 22-0071810T.DWG FBK#327

**DIETER & GARDNER**  
LAND SURVEYORS • PLANNERS  
1641 CONNECTICUT ROUTE 12  
P.O. BOX 335  
GALES FERRY, CT. 06335  
(860) 464-7455  
EMAIL: DIETER.GARDNER@YAHOO.COM

N/F SHIRLEY P. PANDORA  
N/F ARLENE ALLARD  
N/F CITY OF GROTON  
N/F AVERY BROOK HOMES LLC

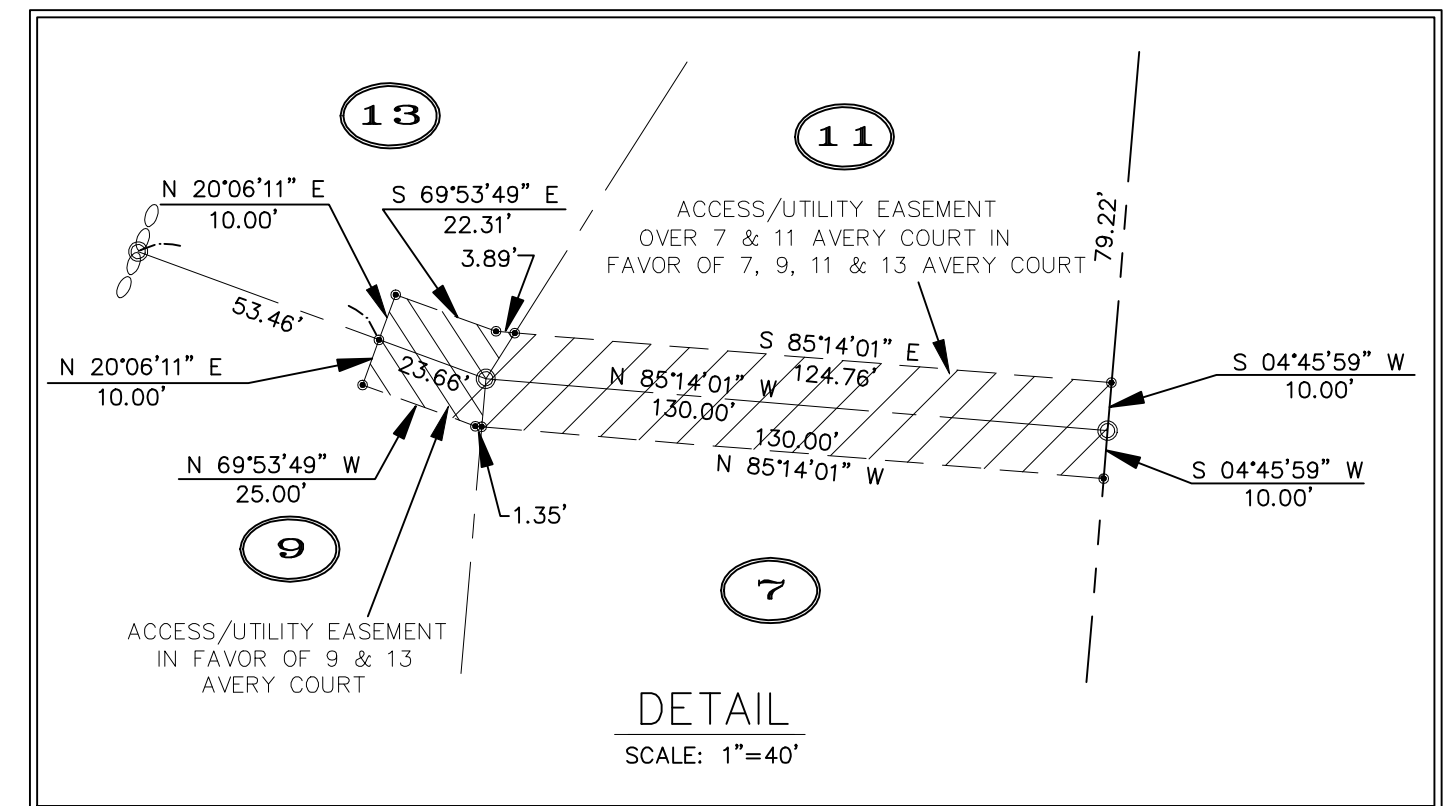
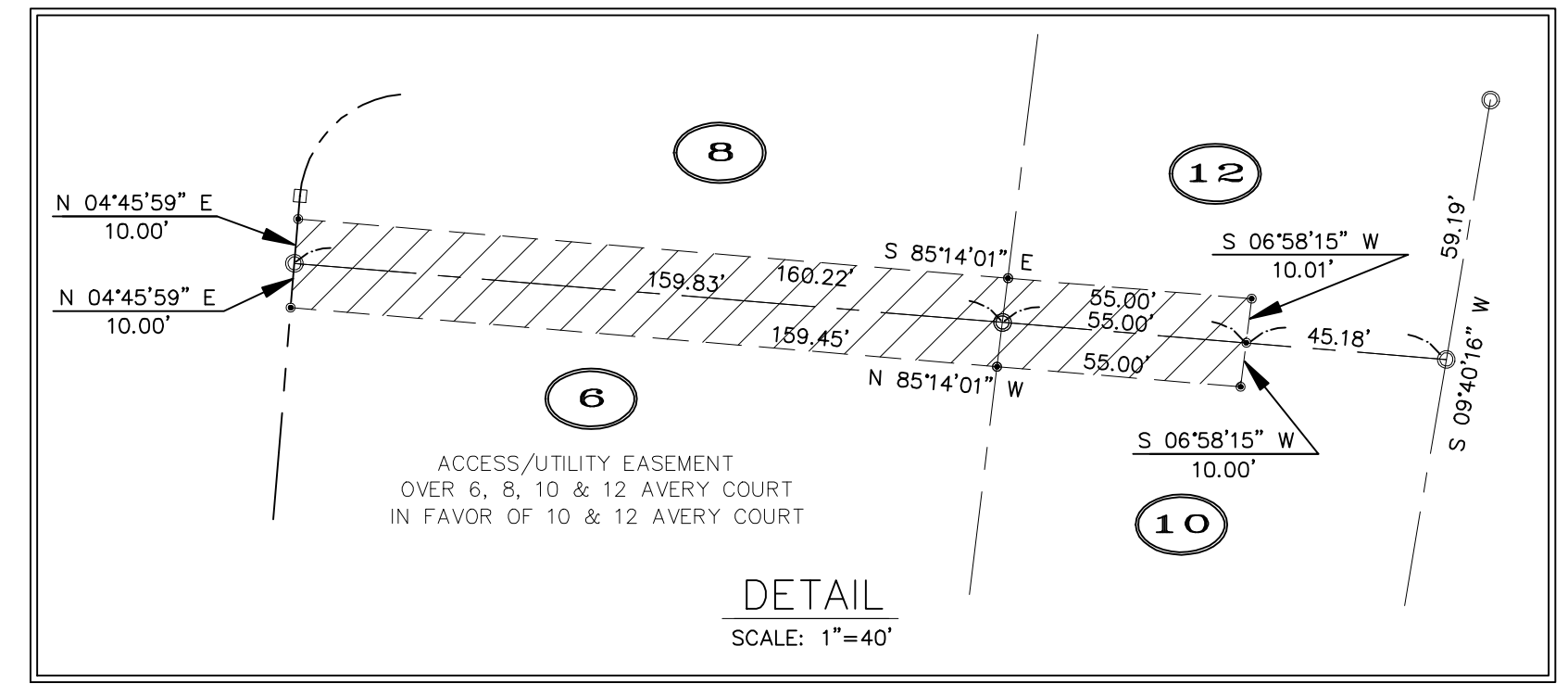
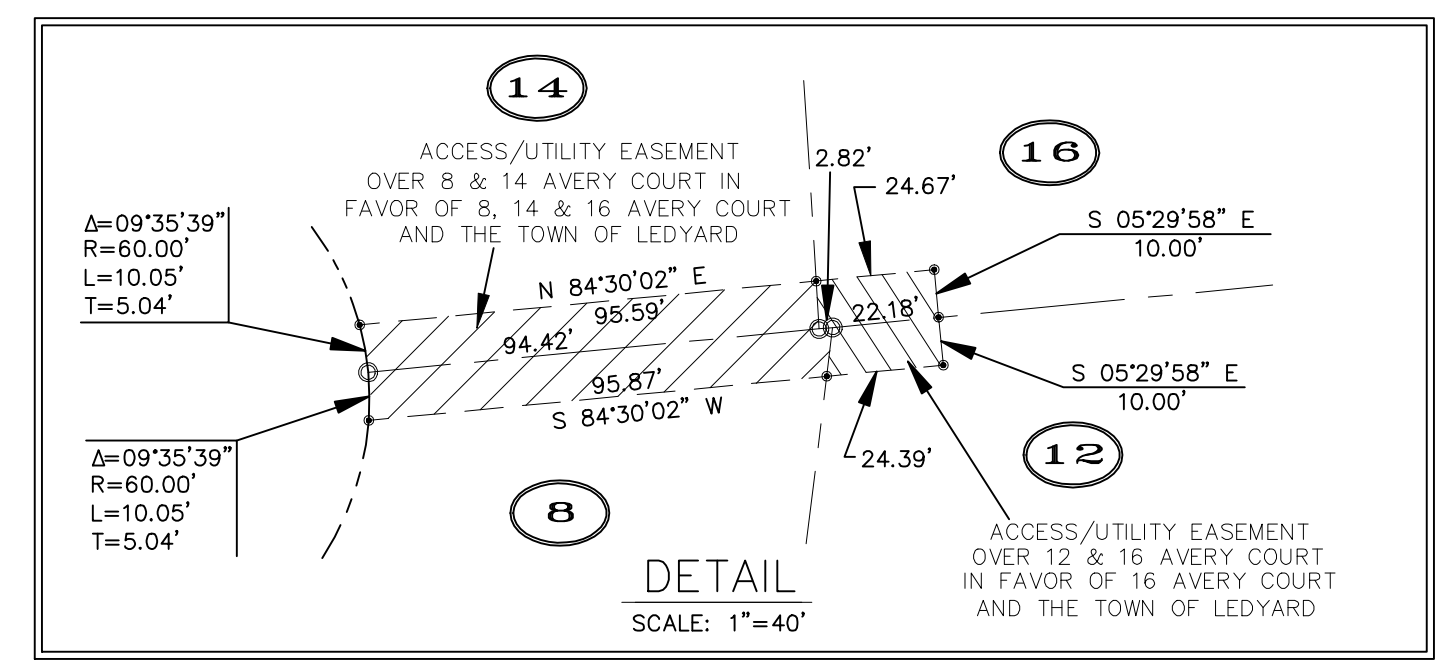
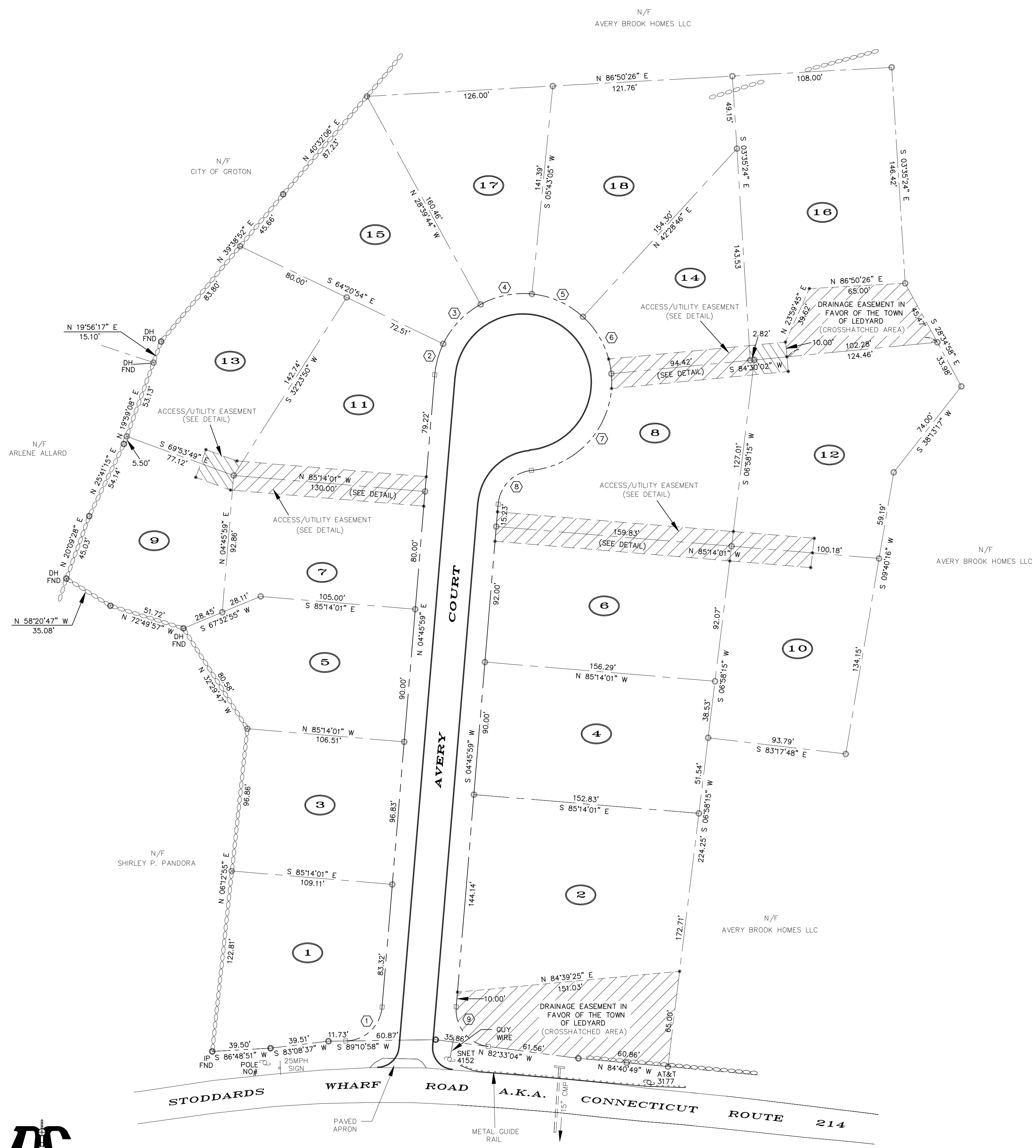

CURVE #	Δ	R	L	T
1	84°24'59"	25.00'	36.83'	22.68'
2	20°53'07"	60.00'	21.87'	11.06'
3	35°41'10"	60.00'	37.37'	19.31'
4	34°22'48"	60.00'	36.00'	18.96'
5	36°45'41"	60.00'	38.50'	19.94'
6	42°01'16"	60.00'	44.00'	23.04'
7	90°06'06"	60.00'	94.35'	60.11'
8	79°50'09"	25.00'	34.83'	20.92'
9	87°19'03"	25.00'	38.10'	23.86'

**PLAN SHOWING RESUBDIVISION PROPERTY OF AVERY BROOK HOMES LLC 96, 98 & 100 STODDARDS WHARF ROAD A.K.A. CONNECTICUT ROUTE 214 LEDYARD, CONNECTICUT SCALE: 1"=40' MARCH 2024**

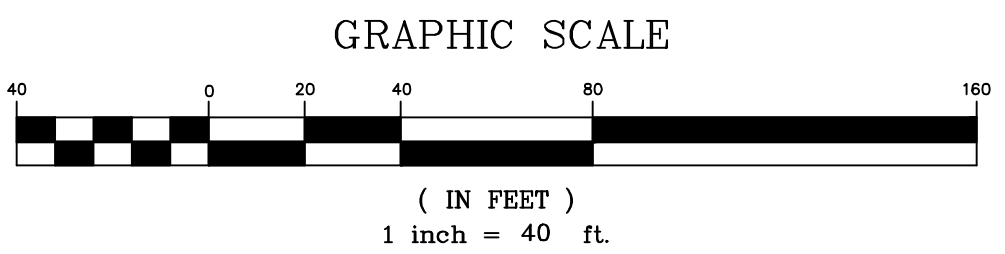

THIS MAP AND SURVEY HAS BEEN PREPARED IN ACCORDANCE WITH SECTIONS 20-300B-1 THROUGH 20-300B-20 OF THE REGULATIONS OF CONNECTICUT STATE AGENCIES—MINIMUM STANDARDS OF ACCURACY, CONTENT AND CERTIFICATION FOR SURVEYS AND MAPS IN THE STATE OF CONNECTICUT, ADOPTED EFFECTIVE JUNE 21, 1996, REVISED OCTOBER 26, 2018. IT IS A BOUNDARY SURVEY BASED ON A DEPENDENT RESURVEY CONFORMING TO HORIZONTAL ACCURACY CLASS A-2. TO MY KNOWLEDGE AND BELIEF, THIS MAP IS SUBSTANTIALLY CORRECT AS NOTED HEREON.

TITLE: LAND SURVEYOR CT No. 14208  
DATE: MARCH 25, 2024